



Disclaimer

This user manual is provided as a free service by FixYourDLP.com. FixYourDLP is in no way responsible for the content of this manual, nor do we guarantee its accuracy. FixYourDLP does not make any claim of copyright and all copyrights remain the property of their respective owners.

About FixYourDLP.com

FixYourDLP.com (<http://www.fixyourdpl.com>) is the World's #1 resource for media product news, reviews, do-it-yourself guides, and manuals.

Informational Blog: <http://www.fixyourdpl.com>

Video Guides: <http://www.fixyourdpl.com/guides>

User Forums: <http://www.fixyourdpl.com/forum>

FixYourDLP's Fight Against Counterfeit Lamps:

<http://www.fixyourdpl.com/counterfeits>

Sponsors:

RecycleYourLamp.org – Free lamp recycling services for used lamps:

<http://www.recycleyourlamp.org>

Lamp Research - The trusted 3rd party lamp research company:

<http://www.lampresearch.com>

Discount-Merchant.com – The worlds largest lamp distributor:

<http://www.discount-merchant.com>



FixYourDLP.com

Sponsored by 

TOSHIBA

OWNER'S MANUAL

3LCD PROJECTOR

TLP-MT3E

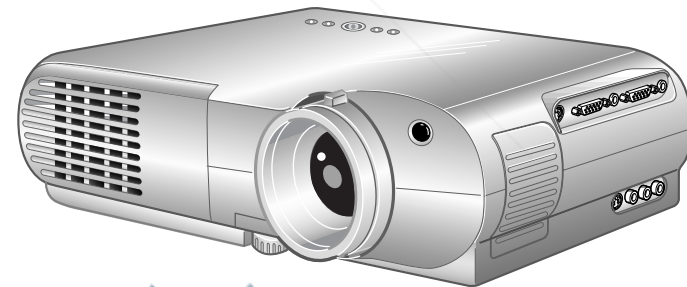

Discount-Merchant.com (800) 281-8860
THE TRUSTED SOURCE FOR PROJECTOR LAMPS AND ACCESSORIES

SAFETY PRECAUTIONS

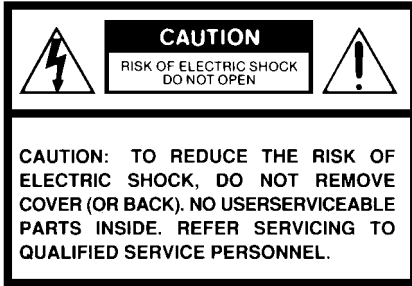

WARNING: TO REDUCE THE RISK OF FIRE OR ELECTRIC SHOCK, DO NOT EXPOSE THIS APPLIANCE TO RAIN OR MOISTURE. DANGEROUS HIGH VOLTAGES ARE PRESENT INSIDE THE ENCLOSURE. DO NOT OPEN THE CABINET. REFER SERVICING TO QUALIFIED PERSONNEL ONLY.

WARNING: This is a Class A product. In a domestic environment this product may cause radio interference in which case the user may be required to take adequate measures.



The lightning flash with arrowhead symbol, within an equilateral triangle, is intended to alert the user to the presence of uninsulated “dangerous voltage” within the product’s enclosure that may be of sufficient magnitude to constitute a risk of electric shock to persons.



The exclamation point within an equilateral triangle is intended to alert the user to the presence of important operating and maintenance (servicing) instructions in the literature accompanying the appliance.



Discount-Merchant.com (800) 281-8860
THE TRUSTED SOURCE FOR PROJECTOR LAMPS AND ACCESSORIES

Before use

IMPORTANT PRECAUTIONS

Save Original Packing Materials

The original shipping carton and packing materials will come in handy if you ever have to ship your LCD projector. For maximum protection, repack the set as it was originally packed at the factory.

Avoid Volatile Liquid

Do not use volatile liquids, such as an insect spray, near the unit. Do not leave rubber or plastic products touching the unit for a long time. They will mar the finish.

Moisture Condensation

Never operate this unit immediately after moving it from a cold location to a warm location. When the unit is exposed to such a change in temperature, moisture may condense on the crucial internal parts. To prevent the unit from possible damage, do not use the unit for at least 2 hours when there is an extreme or sudden change in temperature.

In the spaces provided below, record the Model and Serial No. located at the rear of your LCD projector.

Model No. _____ Serial No. _____

Retain this information for future reference.



Discount-Merchant.com (800) 281-8860
THE TRUSTED SOURCE FOR PROJECTOR LAMPS AND ACCESSORIES

IMPORTANT SAFETY INSTRUCTIONS

CAUTION: PLEASE READ AND OBSERVE ALL WARNINGS AND INSTRUCTIONS GIVEN IN THIS OWNER'S MANUAL AND THOSE MARKED ON THE UNIT. RETAIN THIS BOOKLET FOR FUTURE REFERENCE.

This set has been designed and manufactured to assure personal safety. Improper use can result in electric shock or fire hazard. The safeguards incorporated in this unit will protect you if you observe the following procedures for installation, use and servicing. This unit is fully transistorized and does not contain any parts that can be repaired by the user.

DO NOT REMOVE THE CABINET COVER, OR YOU MAY BE EXPOSED TO DANGEROUS VOLTAGE. REFER SERVICING TO QUALIFIED SERVICE PERSONNEL ONLY.

1. Read Owner's Manual

After unpacking this product, read the owner's manual carefully, and follow all the operating and other instructions.



2. Power Sources

This product should be operated only from the type of power source indicated on the marking label. If you are not sure of the type of power supply to your home, consult your product dealer or local power company. For products intended to operate from battery power, or other sources, refer to the operating instructions.



3. Source of Light

Do not look into the lens while the lamp is on. The strong light from the lamp may cause damage to your eyes or sight.



4. Ventilation

Openings in the cabinet are provided for ventilation and to ensure reliable operation of the product and to protect it from overheating, and these openings must not be blocked or covered. The openings should never be blocked by placing the product on a bed, sofa, rug or other similar surface. This product should not be placed in a built-in installation such as a bookcase or rack unless proper ventilation is provided or the manufacturer's instructions have been adhered to.



Before use

IMPORTANT SAFETY INSTRUCTIONS

5. Heat

The product should be situated away from heat sources such as radiators, heat registers, stoves, or other products (including amplifiers) that produce heat.

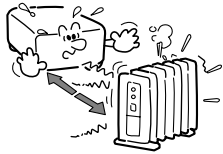

7. Cleaning

Unplug this product from the wall outlet before cleaning. Do not use liquid cleaners or aerosol cleaners. Use a damp cloth for cleaning.



9. Overloading

Do not overload wall outlets; extension cords, or integral convenience receptacles as this can result in a risk of fire or electric shock.



6. Water and Moisture

Do not use this product near water – for example, near a bath tub, wash bowl, kitchen sink, or laundry tub; in a wet basement; or near a swimming pool and the like.

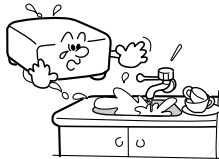

8. Power-Cord Protection

Power-supply cords should be routed so that they are not likely to be walked on or pinched by items placed upon or against them, paying particular attention to cords at plugs, convenience receptacles, and the point where they exit from the product.



10. Lightning

For added protection for this product during storm, or when it is left unattended and unused for long periods of time, unplug it from the wall outlet. This will prevent damage to the product due to lightning and power-line surges.



FixYourDLP.com
Sponsored by DPA

Discount-Merch.com (800) 281-8860
THE TRUSTED SOURCE FOR PROJECTOR LAMPS AND ACCESSORIES

IMPORTANT SAFETY INSTRUCTIONS

11. Object and Liquid Entry

Never push objects of any kind into this product through openings as they may touch dangerous voltage points or short-out parts that could result in a fire or electric shock. Never spill liquid of any kind on the product.



12. Do not place the product vertically

Do not use the product in the upright position to project the pictures at the ceiling, or any other vertical positions. It may fall down and dangerous.

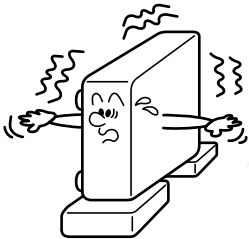

13. Stack Inhibited

Do not stack other equipment on this product or do not place this product on the other equipment.

Top and bottom plates of this product develops heat and may give some undesirable damage to other unit.

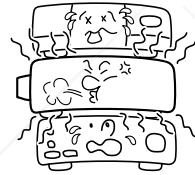

14. Attachments

Do not use attachments not recommended by the product manufacturer as they may cause hazards.



15. Accessories

Do not place this product on an unstable cart, stand, tripod, bracket, or table. The product may fall, causing serious injury to a child or adult, and serious damage to the product. Use only with a cart, stand, tripod, bracket, or table recommended by the manufacturer, or sold with the product. Any mounting of the product should follow the manufacturer's instructions, and should use a mounting accessory recommended by the manufacturer.

A product and cart combination should be moved with care. Quick stops, excessive force, and uneven surfaces may cause the product and cart combination to overturn.

Before use

IMPORTANT SAFETY INSTRUCTIONS

16. Damage Requiring Service

Unplug this product from the wall outlet and refer servicing to qualified service personnel under the following conditions:

- a) When the power-supply cord or plug is damaged.
- b) If liquid has been spilled, or objects have fallen into the product.
- c) If the product has been exposed to rain or water.
- d) If the product does not operate normally by following the operating instructions. Adjust only those controls that are covered by the operating instructions as an improper adjustment of other controls may result in damage and will often require extensive work by a qualified technician to restore the product to its normal operation.
- e) If the product has been dropped or damaged in any way.
- f) When the product exhibits a distinct change in performance – this indicates a need for service.

17. Servicing

Do not attempt to service this product yourself as opening or removing covers may expose you to dangerous voltage or other hazards. Refer all servicing to qualified service personnel.



18. Replacement Parts

When replacement parts are required, be sure the service technician has used replacement parts specified by the manufacturer or have the same characteristics as the original part. Unauthorized substitutions may result in fire, electric shock, or other hazards. (Replacement of the lamp only should be made by users.)

19. Safety Check

Upon completion of any service or repairs to this product, ask the service technician to perform safety checks to determine that the product is in proper operating condition.

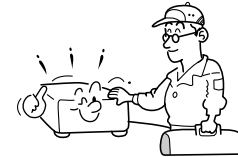

20. If glass components, including lens and lamp, should break, contact your dealer for repair service.

This product incorporates glass components, including a lens and a lamp. If such parts should break, please handle with care to avoid injury and contact your dealer for repair service. The broken pieces of glass may cause injury.



Discount-Merchant.com (800) 281-8860
THE TRUSTED SOURCE FOR PROJECTOR LAMPS AND ACCESSORIES

Contents

Before use

<i>SAFETY PRECAUTIONS</i>	2
<i>IMPORTANT PRECAUTIONS</i>	3
<i>IMPORTANT SAFETY INSTRUCTIONS</i>	4
<i>Part names and functions</i>	9
<i>Power supply cord selection</i>	13

Connections and installation

<i>Connections</i>	14
<i>Projector placement</i>	16

Operations

<i>Picture projection</i>	19
---------------------------------	----

Adjustments

<i>Setting and adjustments on the menu</i>	23
<i>Initial settings – Default</i>	24
<i>Keystone correction – Keystone</i>	26
<i>Projection adjustments – Image</i>	27
<i>Picture adjustments – Picture</i>	28
<i>Sound adjustments – Audio</i>	29
<i>Saving data – Save</i>	30

Maintenance

<i>Trouble indications</i>	31
<i>Air filter, lens and main unit cleaning</i>	32
<i>Lamp replacement</i>	33

Others

<i>Before calling service personnel</i>	34
<i>Input signal</i>	36
<i>Adjustments with RS-232C</i>	40
<i>Specifications</i>	42



FixYourDLP.com

Sponsored by

Discount-Merchant.com (800) 281-8860

THE TRUSTED SOURCE FOR PROJECTOR LAMPS AND ACCESSORIES

Before use

Part names and functions

Main unit

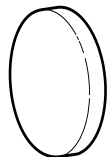

Lens cover

Projection lens

Exhaust holes

Foot adjuster
release button

Foot adjuster

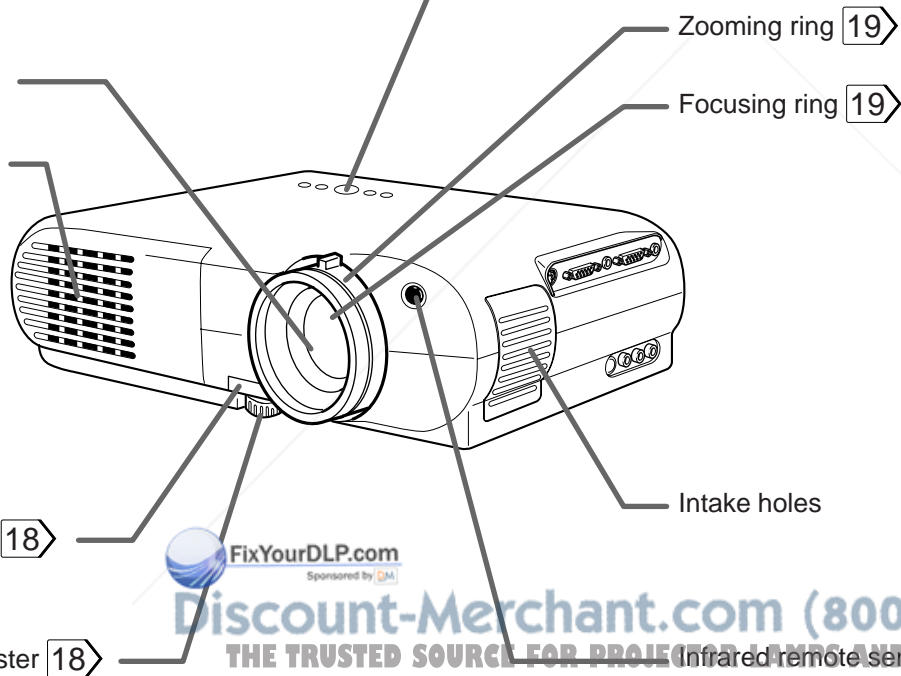

Control panel

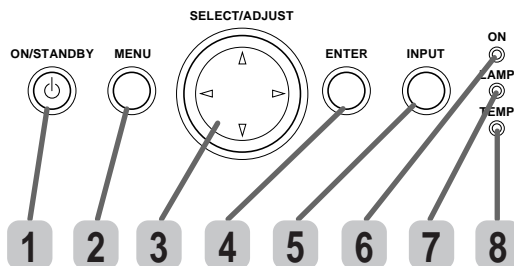

- 1** ON/STANDBY button **19**
To turn the projector on or off.
- 2** MENU button **23**
To display or close the menu.
- 3** SELECT/ADJUST button **24**
(▲/▼/◀/▶)
To select items or adjust values on the menu.
- 4** ENTER button **26**
To enter your selection on the menu.
- 5** INPUT button **19**
To select the input source.
- 6** ON indicator **19** **31**
- 7** LAMP indicator **19** **31**
- 8** TEMP indicator **31**

FixYourDLP.com
Sponsored by DLP

Discount-Merchant.com (800) 281-8860

THE TRUSTED SOURCE FOR PROJECTOR PARTS AND ACCESSORIES

(Continued)

10 Before use

(Continued)

Left side

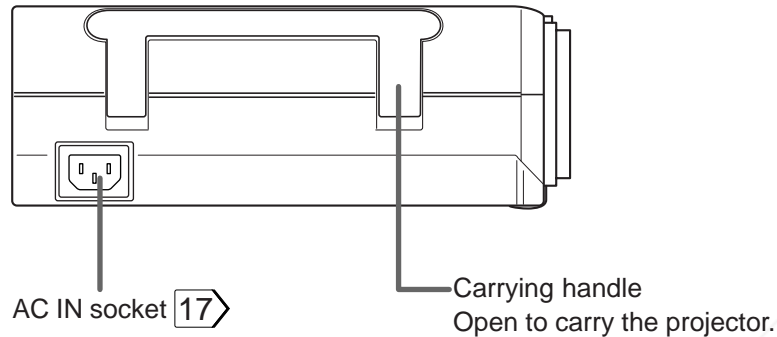

Rear side

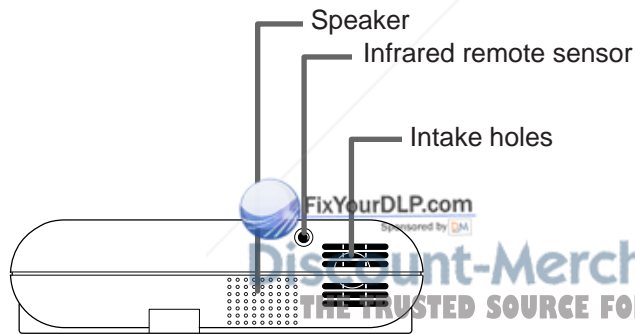

Right side

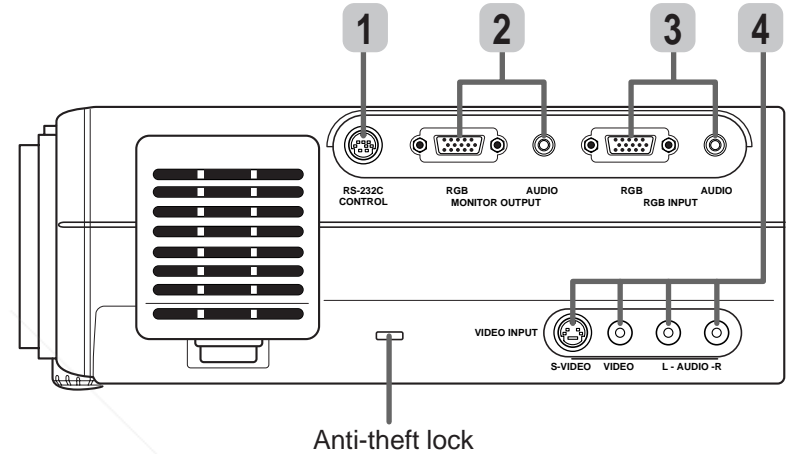

- 1** CONTROL connector **14** **40**
To connect a computer to control the projector.
- 2** MONITOR OUTPUT connectors (RGB output, AUDIO output) **14**
To connect to a monitor or audio equipment.
- 3** RGB INPUT connectors (RGB input, AUDIO input) **15**
To connect a computer or video equipment with component video outputs, etc.
- 4** VIDEO INPUT connectors (S-VIDEO input, VIDEO input, AUDIO input) **14**
To connect a video equipment, etc.

(Continued)

Before use

(Continued)

Remote control

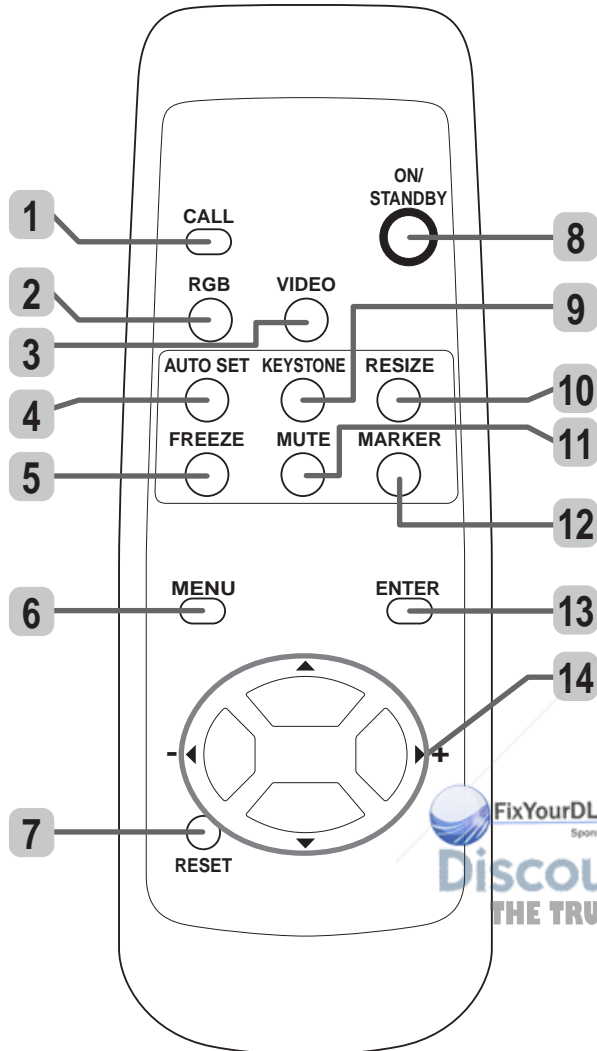

- 1** CALL button **[21]**
To display the current input source and signal status information.
- 2** RGB button **[19]**
To select the RGB input.
- 3** VIDEO button **[19]**
To select S-video input or Video input.
- 4** AUTO SET button **[21]**
To adjust the image automatically.
- 5** FREEZE button **[21]**
To freeze the picture.
- 6** MENU button **[24]**
To display or close the menu.
- 7** RESET button **[25]**
To restore the settings and adjustments to the default.
- 8** ON/STANDBY button **[19]**
To turn the projector on or off.
- 9** KEYSTONE button **[20]**
To correct the keystone distortion of the picture automatically.
- 10** RESIZE button **[22]**
To change the picture size.
- 11** MUTE button **[21]**
To cut off the picture and sound temporarily.
- 12** MARKER button
To display a marker on the screen. Each time the button is pressed, the marker changes the shape, and finally disappears.
- 13** ENTER button **[26]**
To enter your selection on the menu.
- 14** ▲, ▼, ◀(-), ▶(+) buttons **[24]**
 - To select items or adjust values on the menu.
 - To shift a picture after changing its size with the RESIZE button.
 - To move the marker displayed with the MARKER button.

FixYourDLP.com
Sponsored by DLP
Discount-Merch.com (800) 281-8860
THE TRUSTED SOURCE FOR PROJECTOR LAMPS AND ACCESSORIES

(Continued)

12 Before use

(Continued)

Installing batteries

1) Open the cover.

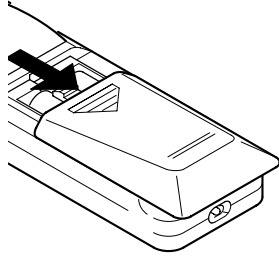

2) Install the batteries.

Make sure that the +/- polarities match the illustration in the compartment.

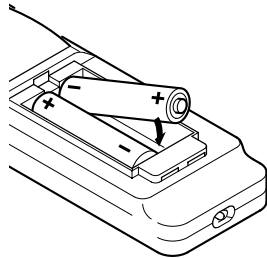

3) Attach the cover.

Notes

Using batteries incorrectly can cause them to leak or burst. Strictly observe the following.

- Install the batteries with their + and – ends facing correctly.
- Do not charge, heat, disassemble, or short the batteries or throw them into a fire.
- Do not leave exhausted batteries in the remote control.
- Do not mix different types of batteries or new and old batteries.
- When you will not be using the remote control for a prolonged period, take the batteries out of the remote control.
- When the remote control stops working or only works from very close distance, replace all the batteries with new ones.
- When replacing the batteries, use a more longer life alkaline batteries.
- If a battery leaks, carefully wipe off any residue inside the battery case before loading new batteries.

Remote control operation

Point the remote control at the infrared remote sensor and press a button.

Front side

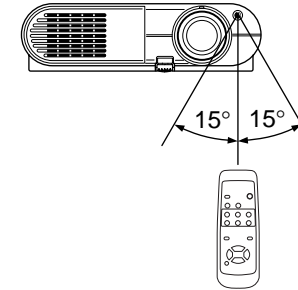

Rear side

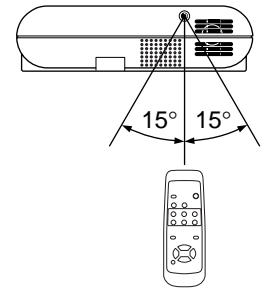

Distance : within about 5 meters from the front of the remote sensor.

Angle : within about 15° of the remote sensor in every direction.



Discount-Merchant.com (800) 281-8860
THE TRUSTED SOURCE FOR PROJECTOR LAMPS AND ACCESSORIES

(Continued)

Before use

(Continued)

Notes

- The remote control may not operate when there is sunlight or other strong light such as a fluorescent lamp shining on the remote sensor.
- Operate the remote control from a position where the remote sensor is visible.
- Do not drop the remote control or otherwise jolt it.
- Keep the remote control out of locations with excessively high temperature or humidity.
- Do not get water on the remote control or place wet objects on it.
- Do not disassemble the remote control.
- Under unusual circumstances the remote control may not operate well due to the location being used or the surroundings. At such times, change the direction of the remote control to the projector and retry the operation.

Power supply cord selection

If your line voltage is 220 to 240, use one of the following types of cable.

In Singapore, use the UK type plug cable. (The UK type plug [MP5004] of this model is approved by PSB.)

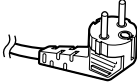
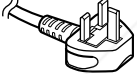
Plug configuration	Plug type	Line voltage
	EURO	220 – 240V
	UK	220 – 240V

Use a 5A fuse which is approved by ASTA or BSI to BSI362.

Always replace the fuse cover after changing the fuse.



Discount-Merchant.com (800) 281-8860
THE TRUSTED SOURCE FOR PROJECTOR LAMPS AND ACCESSORIES

Connections

Connecting video equipment

Check that the power for the projector and computer is off before connecting the cables.

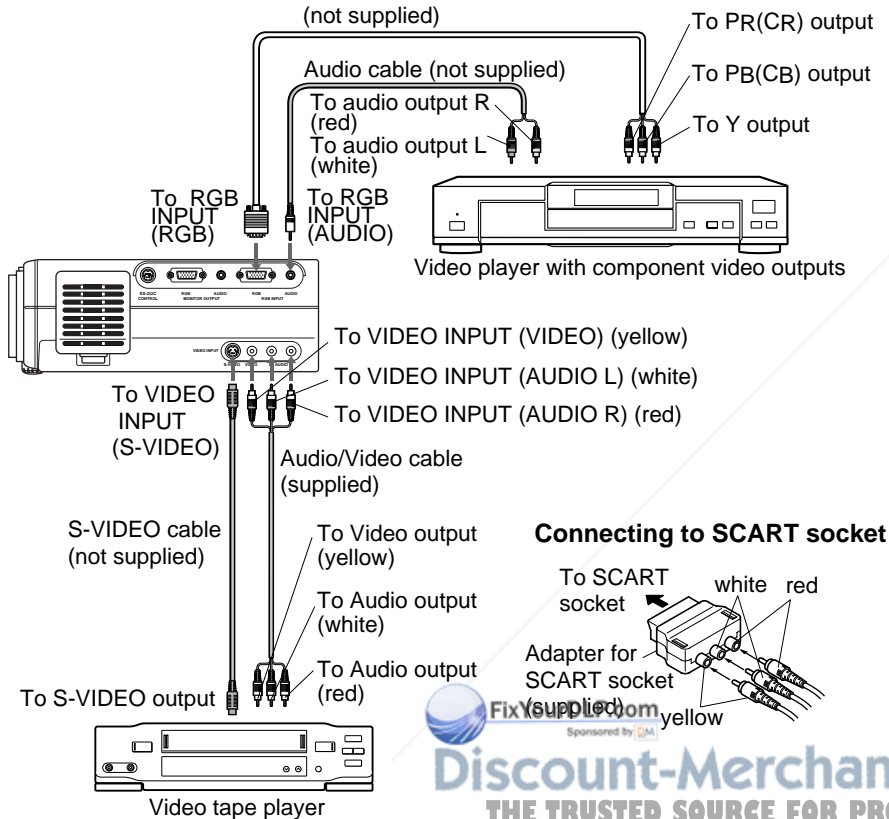

Note

Several video equipments can be connected to the S-VIDEO jack and VIDEO jack separately.

Output terminals

Check that the power for the projector and computer is off before connecting the cables.

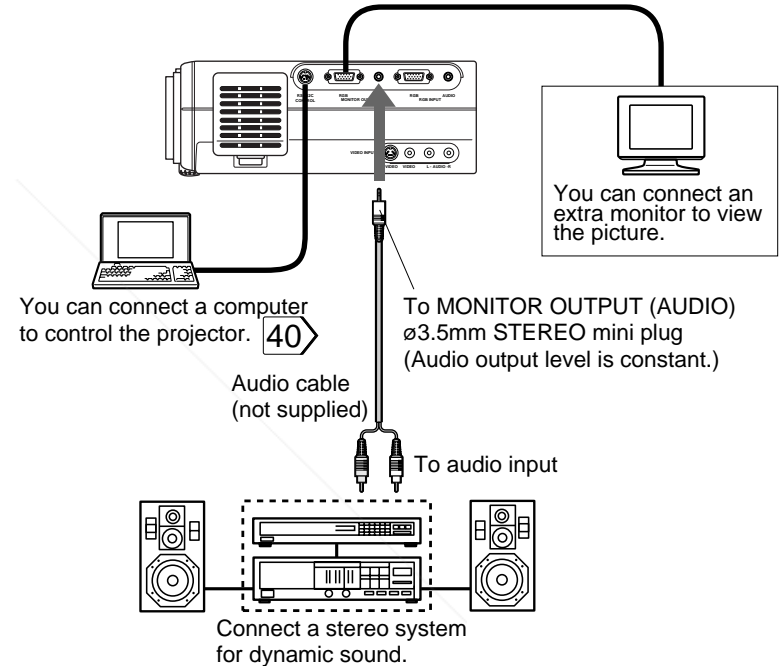

Notes

- Sound of the source which you select is output to the connected stereo system, etc.
- The MONITOR OUTPUT (RGB output) connector always sends out a signal which is input to the RGB INPUT (RGB input) connector regardless of your source selection.
- Even while the projector is in standby mode, the MONITOR OUTPUT (RGB output) connector continues its output.

(Continued)

Connections and installation

(Continued)

Connecting an IBM PC or compatible computer (DOS/V)

Check that the power for the projector and computer is off before connecting the cables.

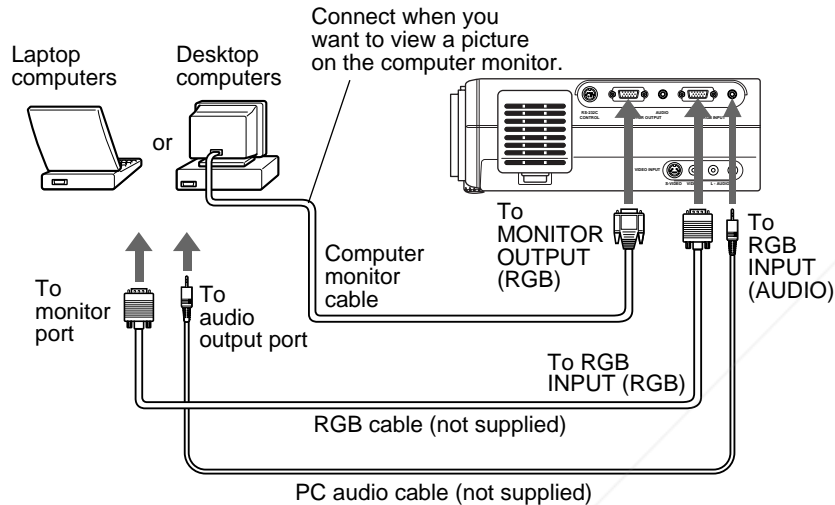

Notes

- The projector cannot be connected to a computer that does not have an analog RGB output terminal. For details, refer to the computer manual.
- You may not be able to connect some computers to the projector. For details, consult the dealer.
- If NTSC/PAL/SECAM signals are input to the RGB INPUT connector, they cannot be displayed. (Input NTSC/PAL/SECAM signals to the VIDEO INPUT jack.)

Connecting a Macintosh computer

- Attach the supplied adapter for Macintosh computers.
- Check that the power for the projector and computer is off before connecting the cables.

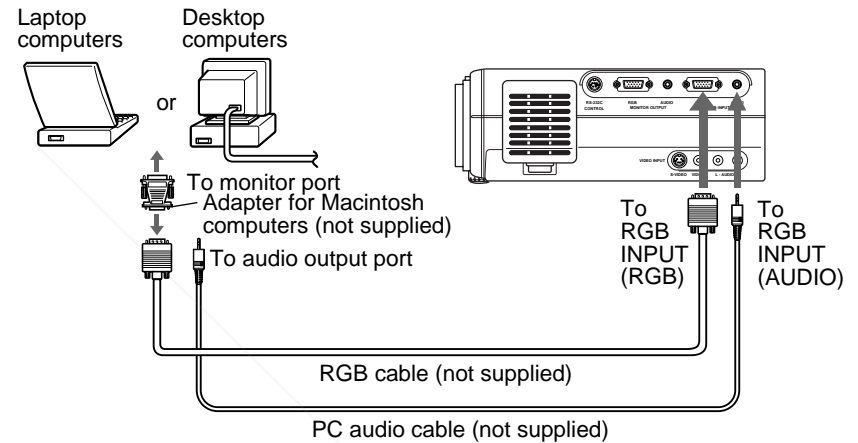

Notes

- The projector cannot be connected to a computer that does not have an analog RGB output terminal. For details, refer to the computer manual.
- You may not be able to connect some computers to the projector. For details, consult the dealer.

Projector placement

There are four ways of installing this projector as shown right. This section explains the standard case of the floor-mounted front projection.

CAUTION

- When a ceiling mount is required, please consult with the dealer.
- When carrying the unit, always handle the carrying handle.

Preparation

- Select a room that can be darkened.
- Refer to the table on the next page [17](#) for the screen size and required distance.

Floor-mounted front projection

Viewing a picture projected on the front of the screen from a floor.

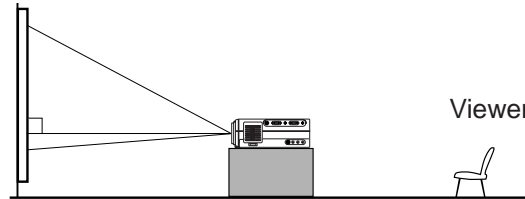

Floor-mounted rear projection

Viewing a picture projected through the back of the screen from a floor installation.

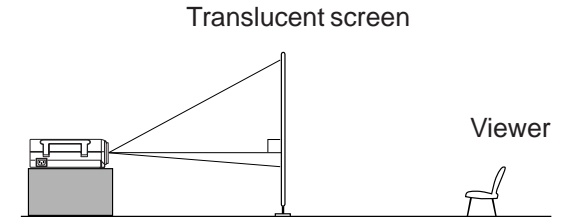

Ceiling-mounted front projection

Viewing a picture projected on the front of the screen from a ceiling installation.

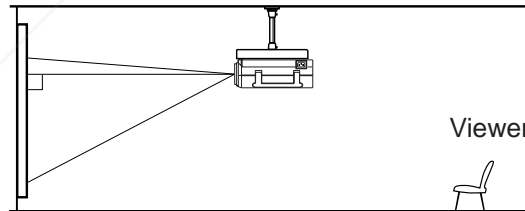

Ceiling-mounted rear projection

Viewing a picture projected through the back of the screen from a ceiling installation.

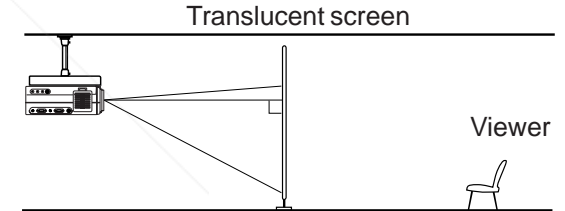

Discount Merchant.com (800) 881-8860
THE TRUSTED SOURCE FOR PROJECTOR LAMPS AND ACCESSORIES

- When installed the projector in the way except the floor-mounted front projection, make the setting of the projecting orientation on the menu [24](#)

Connections and installation

(Continued)

1 Place the projector on a steady, level surface such as a table.

Point the projector squarely at the screen for the best possible picture.

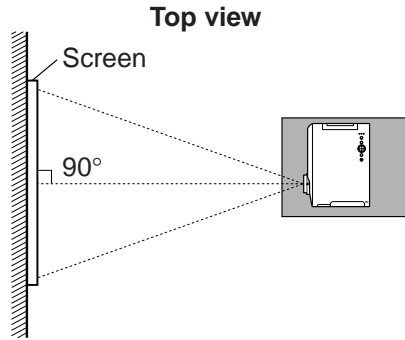

Point the lens straight at the center of the screen as above.

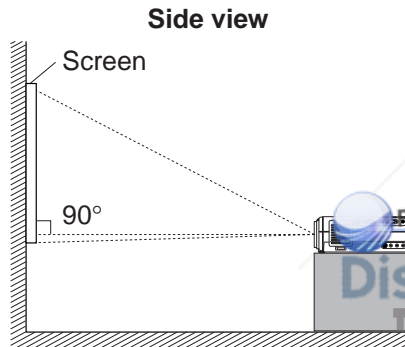

Place the projector horizontally so that the projecting light hits the screen squarely.

2 Adjust the distance between the lens and the screen.

The projection size depends on the distance between the lens and the screen.

Adjust the projection size by changing the distances as shown below.

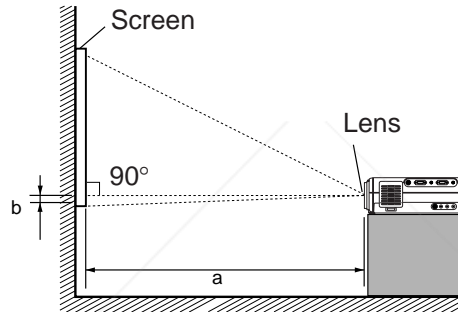

a: Distance between the lens and the screen

b: Distance between the lens height and the bottom of projection area

Screen size (inches)	a (m)		b (cm)
	Minimum (WIDE)	Maximum (TELE)	
23	—	1.132	4
40	1.56	2.017	6
60	2.373	3.059	9
80	3.186	4.1	12
100	3.999	5.142	15
150	6.031	7.746	23
200	8.064	10.35	30
250	10.096	—	38

• The values are approximations.

3 Connect the power cord.

- Insert one end in the AC IN socket on the projector.
- Insert the other end in a wall outlet.

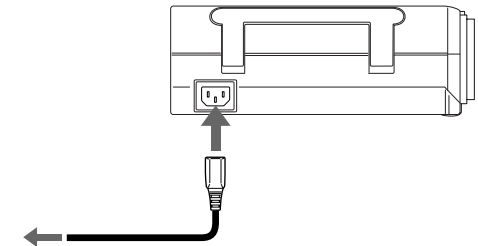

To a wall outlet.

The ON indicator lights in orange and the projector turns to standby mode.

4 Take off the lens cover.

FixYourDLP.com
Sponsored by
Discount-Merchants.com (800) 281-8860
THE TRUSTED SOURCE FOR PROJECTOR REPAIRS AND ACCESSORIES

(Continued)

18 Connections and installation

(Continued)

Notes

- When the projector is moved from a cold location to a warm location, or when the ambient temperature in the projection room has risen suddenly, moisture may condense on the lens or the mirror to blur the projected pictures. In such a case, leave the projector for an adequate time (1 to 2 hours, depending on the room's condition) before using it so it adjusts to the ambient temperature.
- If the screen is exposed to direct sunlight or other strong light, the projected picture becomes too faint to see. Shut out the light with curtains or other means.
- If the screen and the projector are not installed properly, the projected picture may be distorted.
- If the projector is tilted, the picture may be distorted. To obtain the best possible picture, place the projector so it faces the screen squarely.

How to use the foot adjuster

The tilt of the projector can be adjusted using the foot adjuster.

- 1) Lift the front of the projector until a tilt angle desired is obtained and hold down the foot adjuster release button.

The foot adjuster will stretch.

Release the button to lock in position.

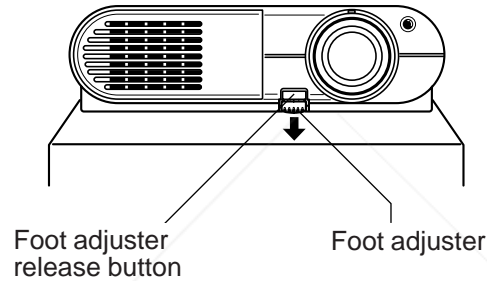

- 2) Turn the foot adjuster to make fine adjustment of the height.

Turn clockwise to lift up.

Turn counterclockwise to lower.

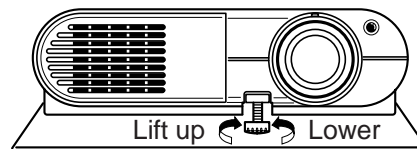

- 3) To put the foot adjuster back, hold down the foot adjuster release button and lower the front slowly.

The foot adjuster will put back.

Note

Be sure to hold the projector when putting the foot adjuster back so as not to let the front fall on your fingers.

Operations

Picture projection

CAUTION

Do not look into the projection lens while operating the projector.

Preparation

- Install and connect the projector properly.
- Take off the lens cover.

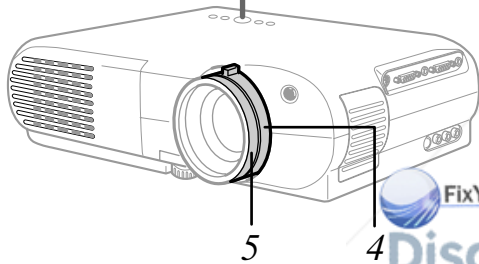
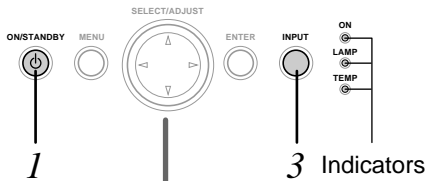
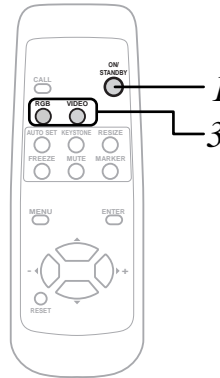

1 Press ON/STANDBY.

Both the ON and LAMP indicators light up in green.

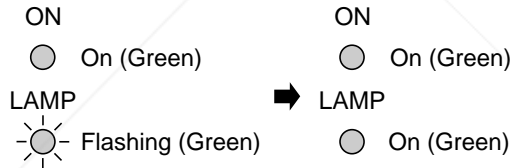

2 Turn on the connected equipment and put it in playback mode.

3 Select the input source.

(On the control panel of the main unit)
Press INPUT repeatedly.
Each time the button is pressed, the source indication on the screen changes as follows:

- RGB: To project pictures from a computer connected to RGB INPUT or a video equipment with component video output jack.
- ↓
- Video: To project pictures from a video equipment, etc. connected to VIDEO jack of VIDEO INPUT.
- ↓
- Y/C: To project pictures from a video equipment, etc. connected to S-VIDEO jack of VIDEO INPUT.

(On the remote control)

RGB: Press RGB.

Video/Y/C: Press VIDEO.

Each time the button is pressed, Video/Y/C is switched.

4 Adjust the picture size by turning the zooming ring.

Turn to the right to enlarge the picture.
Turn to the left to reduce the picture.

5 Focus on the picture by turning the focusing ring.



A still picture is recommended for focusing.

FixYourDLP.com
Sponsored by
Discount-Merchants.com (800) 281-5800
THE TRUSTED SOURCE FOR PROJECTORS AND ACCESSORIES

20 Operations

(Continued)

Notes

- “” is displayed on the screen if the projector does not receive any signal from the connected equipment. Put the equipment in playback mode.
- Due to the lamp characteristic, flickers may occasionally occur in a picture. This is not malfunction of the unit.
- When an RGB source is selected and no signal is sent from the computer for about 30 minutes, the projector turns to standby mode for power saving. It automatically turns on when the signal resumes. Pressing ON/STANDBY also turns it on.
- While operating the projector, “” may be displayed on the screen. This means that the operation cannot be completed.

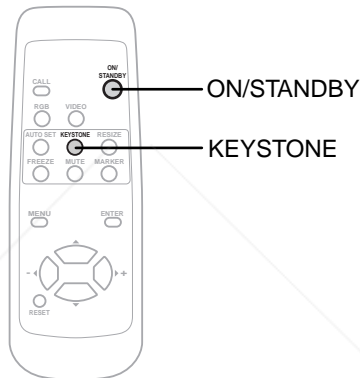
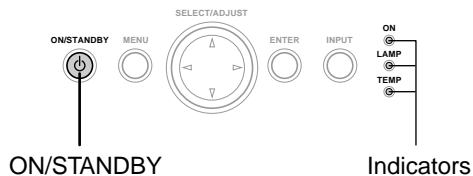

Notes

- Even after turning the power off, the intake and exhaust fans continue to work for a while to cool the inside of the projector.
- Immediately after the power off, the projector may not be turned on while the LAMP indicator is flashing in green.
- Before unplugging the power cord, make sure that the fans are stopped.

Correcting the keystone distortion

A picture may be expanded on the upper side if projected upward from the projector lifted up by the foot adjuster. The projector can correct this keystone distortion automatically.

Press **KEYSTONE**.

The keystone distortion is corrected automatically.

To correct further, make the “Keystone” adjustment on the menu. 

Turning the power off

- 1) Press ON/STANDBY after using the projector.
An instruction message appears.
- 2) Press ON/STANDBY again.

The LAMP indicator turns off, and the projector turns to standby mode. (The ON indicator lights in orange.)

- 3) After confirming the exhaust fan stops, unplug the power cord.

The ON indicator turns off.



Sponsored by 

Discount-Merch.com (800) 281-8860

THE TRUSTED SOURCE FOR PROJECTOR PARTS AND ACCESSORIES

(Continued)

Operations

(Continued)

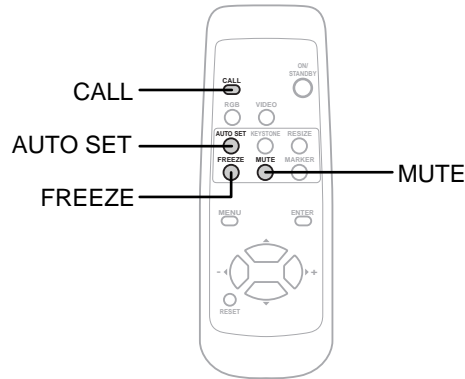

2) Press MUTE again.

The picture is also cut off temporarily.

“” appears.

To restore, press MUTE again.

Note

If you press MUTE while the menu is displayed, the menu disappears.

Freezing the picture

Press FREEZE.

The picture freezes.

“” mark appears on the screen.

To release the picture, press FREEZE again.

Any other operations can also release the picture.

Displaying the input source information

Press CALL.

The current input source and the signal status information is displayed.

To close the display, press CALL again.

Contents of displayed items

[Status]	
Input	:RGB
Signal	:XGA60
Screen	:XGA60
Synchro.	:N/N
Ver./rev.:V01/R01	

Current input source
 Signal system of the input source
 Signal system automatically detected by the projector
 (Mode determination )
 Synchronizing polarity of input signal
 P=Positive N=Negative
 Version number of software

Note

If you press CALL while the menu is displayed, the menu disappears.

Adjusting the image automatically

An image which is flickering, blurred or is not centered, can be adjusted automatically.

Press AUTO SET.

The image is adjusted automatically.

To adjust further, make the “Image” adjustment on the menu. 

Cutting off the picture and sound temporarily

1) Press MUTE.

The sound is cut off temporarily.

“” appears.

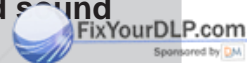

Discount-Merchant.com (800) 281-8860

THE TRUSTED SOURCE FOR PROJECTOR LAMPS AND ACCESSORIES

22 Operations

(Continued)

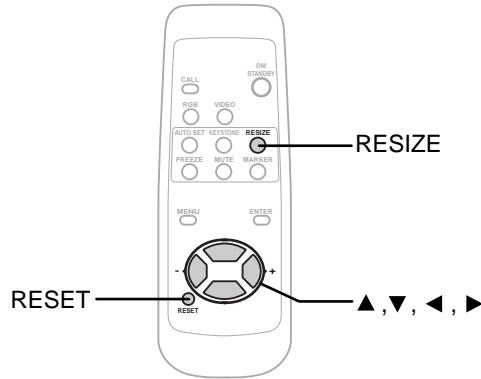

When the picture size is smaller than the projection area:

- ▲ : To move the picture upward
- ▼ : To move the picture down
- ◀ : To move the picture leftward
- ▶ : To move the picture rightward

When the picture size is larger than the projection area:

- ▲ : To view the upper side of the picture
- ▼ : To view the lower side of the picture
- ◀ : To view the left side of the picture
- ▶ : To view the right side of the picture

Notes

- Picture size returns to normal after the power is turned off. The values are not saved.
- You may not change the picture size depending to the signal.
- Pictures of VGA signals, etc. may be slightly inferior in quality at the initial size because they are enlarged.
- The picture returns to the normal position when the RESET button is pressed after the picture is moved.
- The picture may not be projected properly while moving the picture.

Changing the picture size

Pictures are projected at the maximal projection size regardless of the signal types. Optionally you can change the picture size to through size or enlarge it.

Press RESIZE.

Each time the button is pressed, the picture size changes from the center of the picture.

When the picture size does not cover the projection area, the picture can be moved by pressing ▲, ▼, ◀ and ▶.

Discount-Merchant.com
Sponsored by DM

Discount-Merchant.com (800) 281-8860
THE TRUSTED SOURCE FOR PROJECTOR LAMPS AND ACCESSORIES

Adjustments

Settings and adjustments on the menu

Most of adjustments and settings are made on the menu.

To display the menu, press MENU.



The followings are adjustments and settings on the menu. For details, see page in .

When using this projector for the first time, see "Default".

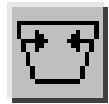

Keystone

26

Auto set : To correct the keystone distortion automatically.

Adjust : To make the correction of keystone distortion beyond the automatic correction.

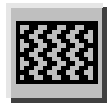

Image

27

Auto sync. : To adjust the image automatically.

Phase : To adjust the phase.

H-position : To shift the image position horizontally

V-position : To shift the image position vertically.

Clock : To adjust the clock frequency.



Picture

28

Contrast : To adjust the contrast.

Brightness : To adjust the brightness.

Color : To adjust the color depth.

Tint : To adjust the tint.

Sharpness : To adjust the sharpness.

R-level : To adjust the amount of red in the picture.

G-level : To adjust the amount of green in the picture.

B-level : To adjust the amount of blue in the picture.



Audio

29

Volume : To adjust the sound volume of the speaker.

Bass : To adjust the bass of the sound output.

Treble : To adjust the treble of the sound output.



Default

24

Language : To select the language for displays.

Proj. mode : To set the projecting orientation according to the way of installation.

RGB input : To set the signal type of RGB input.

Video signal : To set the signal type of video input.

Scrn display : To use or disable on-screen displays.



Save

30

Save data : To save the adjustments and settings on the menu.

All preset : To restore the adjustments and settings on the menu to the factory set.



FixYourDLP.com
Sponsored by

Discount-Merchant.com (800) 281-8860
THE MOST TRUSTED SOURCE FOR PROJECTOR LAMPS AND ACCESSORIES

Initial settings – Default

Make the basic settings for projecting.

Preparation

- Display the image as explained in “Picture Projection”. 19

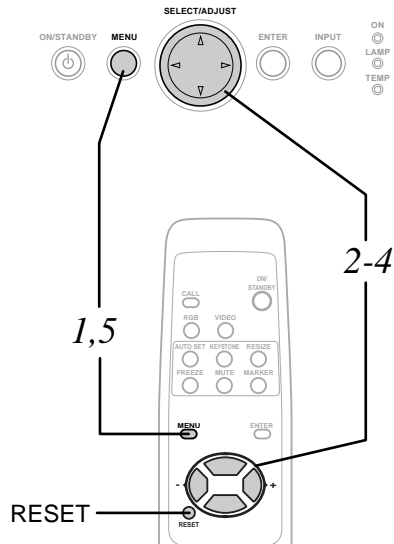

1 Press MENU to display the menu.

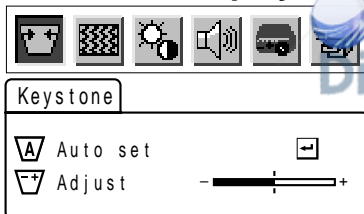

2 Press ◀ or ▶ to select .

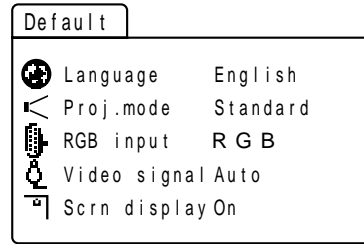

3 Press ▲ or ▼ to select a preferred item.

4 Press ◀ or ▶ to make the setting.

To select another item, go back to step 3.

Language

Select a language for the menu or on-screen displays.

English:	English
Français:	French
Deutsch:	German
Italiano :	Italian
Español :	Spanish
Português :	Portuguese
日本語 :	Japanese

Proj. mode

Confirm your installation type on the chart on page 16.

Standard: Floor-mounted front projection

Rear: Floor-mounted rear projection

Ceiling: Ceiling-mounted front projection

R. ceil.: Ceiling-mounted rear projection

RGB input

To set the signal type of RGB input.

RGB: RGB signal

Y/Pb/Pr: Color difference (Component) video signal from the DVD video player, etc.

Video signal

To set the signal type of video input.

Auto: Automatic signal detection works on video input. If it does not properly, set the signal type of the source from the followings.

NTSC M:	NTSC M signal
NTSC443A:	NTSC4.43A signal
NTSC J:	NTSC J signal
NTSC N:	NTSC N signal
NTSC443B:	NTSC4.43B signal
PAL:	PAL signal
PAL N:	PAL N signal
SECAM:	SECAM signal
PAL443:	PAL4.43 signal
PAL M:	PAL M signal

(Continued)

Adjustments

(Continued)

Scrn display

- | | |
|------|---|
| On: | On-screen displays (indications of input selection, signal absent or mute mode, etc.) appear. |
| Off: | On-screen displays do not appear. |

5 Press MENU.

The menu disappears.

Notes

- These settings are stored until you turn the power off.
- To store the settings even if the power is turned off, follow the procedure of “Saving data”. [30](#)
- Pressing RESET will return the adjustment or setting currently selected to default.



Discount-Merchant.com (800) 281-8860
THE TRUSTED SOURCE FOR PROJECTOR LAMPS AND ACCESSORIES

Keystone correction – Keystone

Preparation

- Display the image as explained in “Picture Projection”. **19**

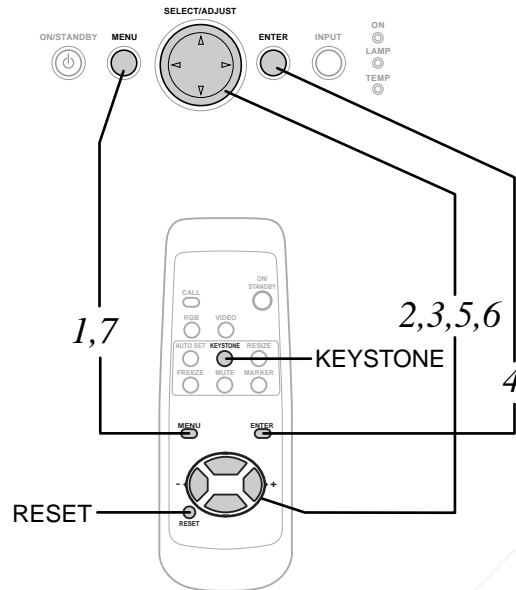

1 Press MENU to display the menu.

2 Press ◀ or ▶ to select .



3 Press ▼ to select “Auto set”.

4 Press ENTER.

The keystone distortion is corrected automatically. For further correction, follow the below steps.

5 Press ▼.

6 Press ◀ or ▶ to correct the distortion.

- ◀ (-): To reduce the upper width.
- ▶ (+): To reduce the lower width.

Press MENU.

The menu disappears.

Notes

- Pressing KEYSTONE on the remote control can also correct the keystone distortion automatically. **20**
- These adjustments are stored until you turn the power off.
- Pressing RESET will return the adjustment or setting currently selected to default.
- Pictures may be slightly deteriorated by the keystone correction.

0 degrees setting for the automatic keystone correction

Depending on the operating condition such as vibration, the distortion may be beyond the automatic keystone correction. The horizontal condition setting (0 degrees setting) may be disordered. In such a case, perform the following 0 degrees setting to correct the distortion.

- Place the projector on a level surface.
- On the menu, select “Auto set” in “Keystone”.
- Press RESET.

Notes

- Do not make the 0 degrees setting on an inclined or unstable surface or in a shaky place as it may not be performed properly.
- To store this setting even if the power is turned off, follow the procedure of “Saving data”. **30**

Adjustments

Projection adjustments – Image

Preparation

- Display the image as explained in “Picture Projection”. **19**

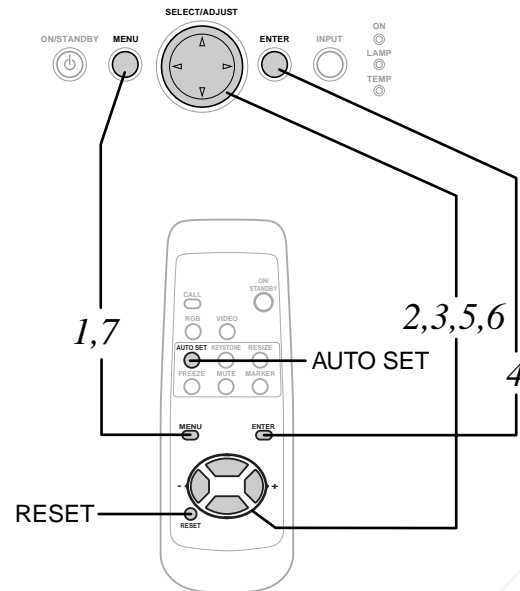

1 Press MENU to display the menu.

2 Press ◀ or ▶ to select .

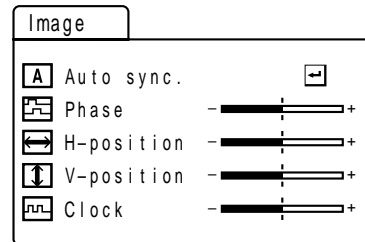

3 Press ▼ to select “Auto sync.”

4 Press ENTER.

The image is automatically adjusted. For further adjustments, follow the below steps.

5 Press ▲ or ▼ to select a preferred item.

6 Press ◀ or ▶ to adjust the item.

To select another item, go back to step 5.

Phase: To reduce flickers.

H-position: To shift the image to the left (–), to the right (+).

V-position: To shift the image down (–), to up (+).

Clock To remove vertical stripes.

7 Press MENU.

The menu disappears.

Notes

- When performing the automatic projection adjustment, use a bright and distinctly edged picture.
- Pressing AUTO SET on the remote control can also adjust the image automatically. **21**
- If you project an image from a computer with an LCD screen while monitoring the image on the computer, the image may not be projected properly, depending on the computer model. In this case, turn off the computer display, or make the necessary picture adjustments on the projector. For details on controlling the computer display, etc., refer to the computer's manual and description on the software for the computer used.
- During adjustments of “H-position” or “V-position”, the image may not be projected properly.
- While using, an aberration of the phase may occur. In that case, adjust “Phase” again.
- Some item may be displayed in gray depending on an input source. The item displayed in gray cannot be adjusted and/or set.
- These adjustments are stored until you turn the power off.
- To store the adjustments even if the power is turned off, follow the procedure of “Saving data”. **30**
- Pressing RESET will return the adjustment or setting currently selected to default.

Picture adjustments – Picture

Preparation

- Display the image as explained in “Picture Projection”. 19

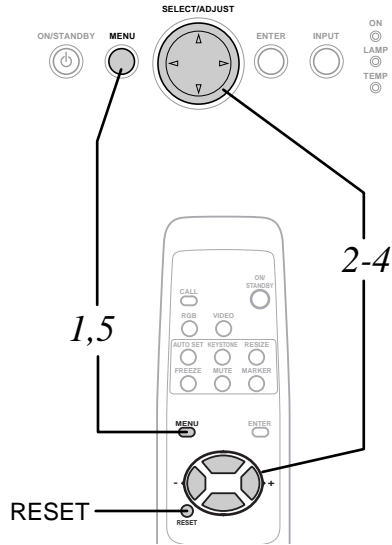

1 Press MENU to display the menu.

2 Press ◀ or ▶ to select



3 Press ▲ or ▼ to select a preferred item.

4 Press ◀ or ▶ to adjust the item.

To select another item, go back to step 3.

- : ◀ + : ▶
- Contrast : (–) Lower
(+) Higher
- Brightness: (–) Darker
(+) Brighter
- Color: (–) Duller
(+) Brighter
- Tint: (–) Redder
(+) Greener
- Sharpness: (–) Softer
(+) Sharper
- R-level: (–) To reduce red
(+) To increase red
- G-level: (–) To reduce green
(+) To increase green
- B-level: (–) To reduce blue
(+) To increase blue

5 Press MENU.

The menu disappears.

Notes

- When the RGB is inputted and when the video signal (also Y/Pb/Pr signal) is inputted, different settings can be adjusted and stored separately.
- Some item may be displayed in gray depending on an input source. The item displayed in gray cannot be adjusted and/or set.
- These adjustments are stored until you turn the power off.
- To store the adjustments even if the power is turned off, follow the procedure of “Saving data”. 30
- Pressing RESET will return the adjustment or setting currently selected to default.

Adjustments

Sound adjustments – Audio

Preparation

- Display the image as explained in “Picture Projection”. **19**

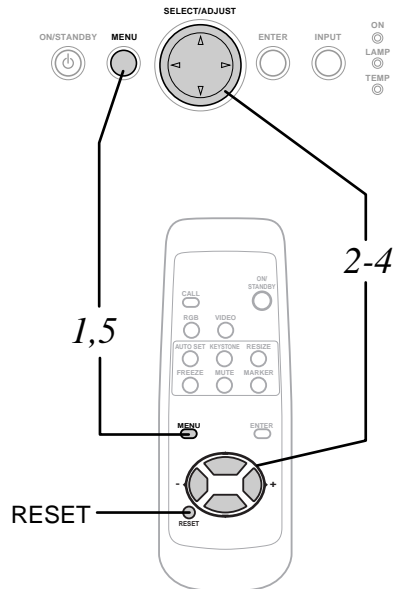

1 Press MENU to display the menu.

2 Press ◀ or ▶ to select .

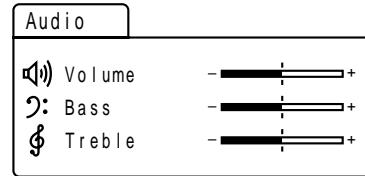

3 Press ▲ or ▼ to select a preferred item.

4 Press ◀ or ▶ to adjust the item.

To select another item, go back to step 3.

- : ◀ + : ▶

Volume : (-) To turn down.
 (+) To turn up.

Bass: (-) To reduce the bass.
 (+) To increase the bass.

Treble: (-) To reduce the treble.
 (+) To increase the treble.

5 Press MENU.

The menu disappears.

Notes

- These adjustments are stored until you turn the power off.
- To store the adjustments even if the power is turned off, follow the procedure of “Saving data”. **30**
- Pressing RESET will return the adjustment or setting currently selected to default.

30 Adjustments

Saving data – Save

Preparation

- Display the image as explained in “Picture Projection”. 19

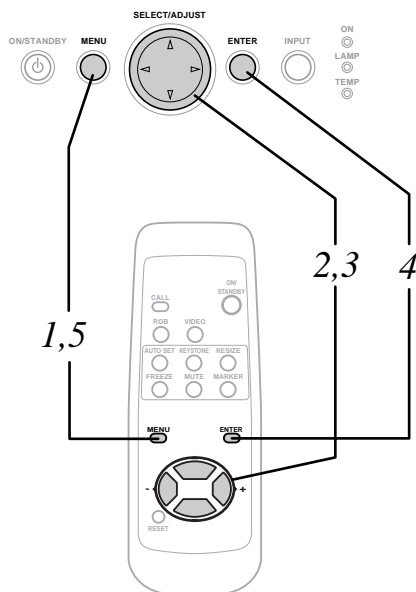

1 Press MENU to display the menu.

2 Press ◀ or ▶ to select  .

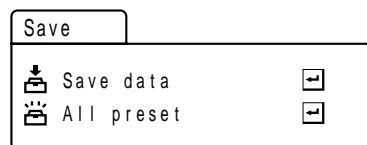

3 Press ▲ or ▼ to select a preferred item.

Save data : To save the adjustments and settings on the menu.

All preset : To restore the adjustments and settings on the menu to the factory set.

4 Press ENTER.

5 Press MENU.

The menu disappears.



Discount-Merchant.com (800) 281-8860

THE TRUSTED SOURCE FOR PROJECTOR LAMPS AND ACCESSORIES

Maintenance

Trouble indications

If there is some problem inside the projector, the indicators light up or flash.

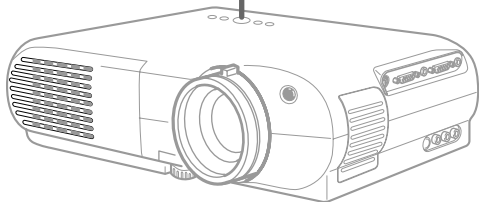

ON	Off or lit (red)
LAMP	–
TEMP	–

The power does not come on.

→ Malfunction of the unit.

- Unplug the power cord and call the dealer.

ON	Lit (red)
LAMP	Lit (red)
TEMP	–

The lamp turns off or does not light up.

→ The lamp's end, or malfunction of the unit.

- Lamp's life length is over, replace the lamp with new one. **33**
- Unplug the power cord and call the dealer.

ON	Lit (red)
LAMP	–
TEMP	Lit (red)

The power turns off or does not come on.

→ The inside is too hot, or the projector has been working in an area of high temperature.

- Place the projector correctly so the intake and exhaust fans' holes are not covered.
- Turn the projector off, and leave it for a while, and turn it on again.
- Clean the air filter. **32**

ON	Lit (red)
LAMP	–
TEMP	Flashing (red)

The power turns off or does not come on.

→ Trouble with the intake fan.

- Unplug the power cord and call the dealer.

ON	Lit (red)
LAMP	–
TEMP	Flashing (orange)

The power turns off or does not come on.

→ Trouble with the exhaust fan.

- Unplug the power cord and call the dealer.

Note

Before attempting any maintenance, unplug the power cord.



Discount-Merchant.com (800) 281-8860
THE TRUSTED SOURCE FOR PROJECTOR LAMPS AND ACCESSORIES

Air filter, lens and main unit cleaning

CAUTION

If you use the projector mounted on the ceiling, ask the dealer to carry out the maintenance such as cleaning.

Cleaning the air filter

The filter under the air filter cover is the device to shut out dusts or dregs.

Do not use the projector with the filter taken off. Give a frequent clean especially to the air filter. (The cleaning period is once per about 50 hours).

- 1) Unplug the power cord.
- 2) Take off the air filter cover.

The filter is on the right side of the projector. Pull up the filter tabs.

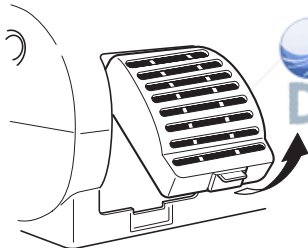

- 3) Clean the air filter cover.

Remove dust and stains with a vacuum cleaner.

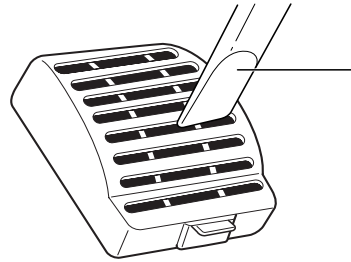

Cleaner's nozzle

- 4) Attach the air filter cover.

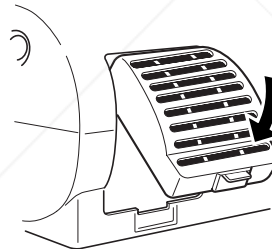

Notes

- When the air filter is dusty, the ventilation is impaired. This causes the temperature inside the projector to rise, and may damage the unit.
- Attach the air filter cover firmly after the cleaning. If it is not set correctly, the dusts will enter and they will be projected and overlapped on the picture.

Cleaning the lens

Use a blower or a lens cleaner to clean the lens.

Never rub or tap the lens with a hard object as the lens surface is fragile.

Cleaning the main unit

- Pull out the power cord before cleaning.
- Use a soft cloth to wipe off stains from the surface.
- To remove difficult stains, use a soft cloth slightly moistened with a weak solution of synthetic detergent and water, and finish with a soft, dry cloth.

Replacing the intake, exhaust fans and air filter

To maintain the efficiency of the projector, replace the intake and exhaust fans about every two to three years.

Ask the dealer for the replacement.

Maintenance

Lamp replacement

The lamp will eventually begin to project dark or dull pictures and finally will not light up. (Lamp's life length depends on the use condition.) In such a case, replace the lamp with new one.

CAUTION

- If you use the projector mounted on the ceiling, ask the dealer to carry out the maintenance such as cleaning or replacement of the lamp.
- When replacing, always use lamp "TLPL8" (sold separately). For detail, refer to TLPL8 instruction.
- If you have been using the projector, the lamp will be very hot, and may cause burn injuries. Wait for the lamp to cool (for longer than 1 hour) before replacing it.
- If the lamp should break, please handle with care to avoid injury due to broken pieces and contact your dealer for repair service.

1 Unplug the power cord.

2 Wait until the lamp gets cold enough.

3 Take off the lamp cover on the bottom panel.

Loosen two screws, and pull off the lamp cover.

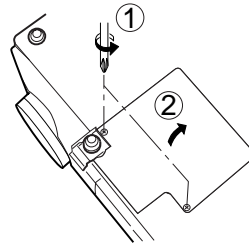

4 Pull out the lamp.

Loosen the two fixing screws, and lift up the handle to pull out the lamp.

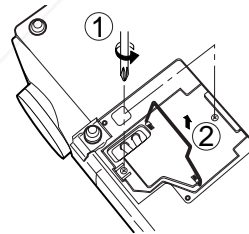

5 Load a new lamp.

Slide until it hits the bottom and tighten the two fixed screws.

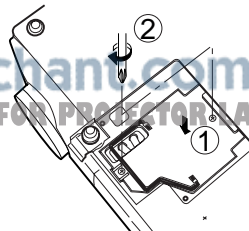

6 Attach the lamp cover.

Slide the cover in place and tighten two screws.

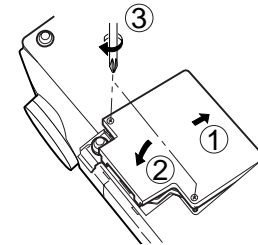

7 Reset the lamp timer.

Refer to the lamp instructions for resetting.

Notes

- The projector displays the total working time at every 1,000 hours (only when plugged in and turned on; ex. ">1000H", ">2000H").
- The lamp should be replaced if the total working time exceeds about 2,000 hours.
- Attach the lamp cover firmly after replacing the lamp. If it is not set correctly, the power will not turn on.
- Use a new lamp when replacing it.
- The lamp is made of glass and is very fragile. Do not touch the lamp with your bare hands and do not jolt or damage it. Do not use an exhausted lamp.

Before calling service personnel

Check the following points before asking for support service.

Refer also to "Trouble indications". **31**

The power does not come on.

- The power cord is disconnected.
→ Firmly plug in the power cord. **17**
- The lamp cover is not attached correctly.
→ Attach the cover correctly. **33**

The power turns off while using the projector.

- The ambient temperature of the projection room is too high.
→ Lower the ambient temperature of the projection room, and turn the power on.

No image appears.

- The lens cover is on.
→ Take off the lens cover. **1**
- The wrong input is selected.
→ Select the input source correctly. **19**
- The muting mode is on.
→ Press MUTE to restore the picture. **21**

- The "Brightness" adjustment is at its darkest.
→ Make the "Brightness" adjustment. **28**
- The source is not correctly connected to the projector.
→ Connect the source correctly to the projector. **14**

No sounds are heard.

- The wrong input is selected.
→ Select the input source correctly. **19**
- The audio muting mode is on.
→ Press MUTE to restore the sound. **21**
- The sound volume is at the minimum.
→ Adjust the sound volume on the menu. **29**
- The source is not correctly connected to the projector.
→ Connect the source correctly to the projector. **14**

The images are blurred. Focusing is uneven.

- The lens is dirty.
→ Clean the lens.
Use a lens cleaner to clean the lens. **32**

- The picture is out of focus.
→ Focus the picture. **19**
- The projection distance is not appropriate.
→ Adjust the distance properly. **17**
- The projecting light is not hitting the screen squarely.
→ Adjust the projecting direction so that the light hits the screen squarely. **17**
- The "Brightness", "Contrast", "Sharpness" or "Phase" adjustments are not correct.
→ Make the "Image" or "Picture" adjustments. **27** **28**

The pictures are dim.

- The "Brightness" or "Contrast" adjustments are not correct.
→ Make the "Picture" adjustments. **28**
- The lamp life is ending.
→ Replace the lamp. **33**

The colors are faint. The colors are strange.



- The "Color", "Tint", "R-Level", "G-Level" or "B-Level" adjustments are not correct.
→ Make the "Picture" adjustments. **28**
- The lamp life is ending.
→ Replace the lamp. **33**

 **Discount-Merchant.com** (800) 281-8840
THE TRUSTED SOURCE FOR PROJECTOR LAMPS AND ACCESSORIES

Others

(Continued)

The remote control does not work.

- The remote control is not facing the remote sensor.
 - Face the remote control transmitter toward the remote sensor on the projector. 
- The remote control is too far.
 - Operate within about 5 meters. 
- There is an obstruction between the remote control and the remote sensor.
 - Remove the obstacle.
- The batteries are exhausted.
 - Replace the batteries. 



Discount-Merchant.com (800) 281-8860
THE TRUSTED SOURCE FOR PROJECTOR LAMPS AND ACCESSORIES

Input signal

Mode determination and signal system

⊙ : full compatible ○ : dot resizing display
 □ : simplified display ● : high resolution serial transfer control

Signal		Frequency		Resolution (line)		Synchronizing	Default	Remarks
Mode	System	Horizontal (kHz)	Vertical (Hz)	Horizontal	Vertical	H/V		
NTSC	NTSC	15.734	59.940	664	484	N/N	●	VIDEO IN
PAL/SECAM	PAL/SECAM	15.625	50.000	756	574	N/N	●	VIDEO IN
NTSC/DTV480i	Digital broadcasting	15.750	60.000	720/640	480	N/N	●	RGB IN
DTV480P/VGA60Hz	Digital broadcasting	31.500	60.000	720/640	480	N/N	○	RGB IN
DTV720P	Digital broadcasting	47.500	60.000	1280	720	N/N	○	RGB IN
HDTV/DTV1080i	Hi-Vision/Digital broadcasting	33.750	60.000	1920	1080	N/N	○	RGB IN
NEC24K	PC98 Standard	24.830	56.420	640	400	N/N	⊙	RGB IN
TEXT70	VGA-350	31.470	70.090	640	350	P/N	⊙	RGB IN
TEXT70	VGA-400	31.470	70.090	640	400	N/P	⊙	RGB IN
TEXT85	VGA 85Hz-1	37.861	85.080	640	350	P/N	⊙	RGB IN
TEXT85	VGA 85Hz-2	37.861	85.080	640	400	N/P	⊙	RGB IN
VGA60	VGA 60Hz	31.470	59.940	640	480	N/N	⊙	RGB IN
VGA72	VGA 72Hz	37.861	72.809	640	480	N/N	⊙	RGB IN
VGA75	VGA 75Hz	37.500	75.000	640	480	N/N	⊙	RGB IN
VGA85	VGA 85Hz-4	43.269	85.008	640	480	N/N	⊙	RGB IN
MAC13	MAC-13"	35.000	66.667	640	480	- / -	⊙	RGB IN
SVGA56	SVGA 56Hz	35.156	56.250	800	600	P/P	⊙	RGB IN
SVGA60	SVGA 60Hz	37.879	60.317	800	600	P/P	⊙	RGB IN
SVGA72	SVGA 72Hz	48.077	72.188	800	600	P/P	⊙	RGB IN
SVGA75	SVGA 75Hz	46.875	75.000	800	600	P/P	⊙	RGB IN
SVGA85	SVGA 85Hz	53.674	85.061	800	600	P/P	⊙	RGB IN
MAC16	MAC-16"	49.724	74.550	832	624	- / -	⊙	RGB IN
XGA43i	XGA 43Hz interlace	35.522	43.479x2	1024	768	P/P	○	RGB IN



 Discount-Projector.com (800) 281-8860

 THE TRUSTED SOURCE FOR PROJECTOR LAMPS AND ACCESSORIES

Others

(Continued)

: full compatible : dot resizing display
 : simplified display : high resolution serial transfer control

Signal		Frequency		Resolution (line)		Synchronizing	Default	Remarks
Mode	System	Horizontal (kHz)	Vertical (Hz)	Horizontal	Vertical	H/V		
XGA60	XGA 60Hz	48.363	60.004	1024	768	N/N	<input type="radio"/>	RGB IN
XGA70	XGA 70Hz	56.476	70.069	1024	768	N/N	<input type="radio"/>	RGB IN
XGA75	XGA 75Hz	60.023	75.029	1024	768	P/P	<input type="radio"/>	RGB IN
XGA85	XGA 85Hz	68.677	84.997	1024	768	N/N	<input type="radio"/>	RGB IN
MAC19	MAC-19"	60.197	74.872	1024	768	N/N	<input type="radio"/>	RGB IN
SXGA75-1	SXGA 75Hz	67.500	75.000	1152	864	P/P	<input type="radio"/>	RGB IN
MAC21	MAC-21"	68.681	75.062	1152	870	- / -	<input type="radio"/>	RGB IN
SXGA60-1	SXGA 60Hz	60.000	60.000	1280	960	P/P	<input type="radio"/>	RGB IN
SXGA85-1	SXGA 85Hz	85.938	85.002	1280	960	P/P	<input type="checkbox"/>	RGB IN
SXGA43i	SXGA 43Hz interlace	46.433	43.436x2	1280	1024	P/P	<input type="radio"/>	RGB IN
SXGA60-2	SXGA 60Hz	63.981	60.020	1280	1024	P/P	<input type="radio"/>	RGB IN
SXGA75-2	SXGA 75Hz	79.976	75.025	1280	1024	P/P	<input type="radio"/>	RGB IN
SXGA85-2	SXGA 85Hz	91.146	85.024	1280	1024	P/P	<input type="checkbox"/>	RGB IN
UXGA60	UXGA 60Hz	75.000	60.000	1600	1200	P/P	<input type="checkbox"/>	RGB IN
UXGA65	UXGA 65Hz	81.130	65.000	1600	1200	P/P	<input type="checkbox"/>	RGB IN
UXGA70	UXGA 70Hz	87.500	70.000	1600	1200	P/P	<input type="checkbox"/>	RGB IN
UXGA75	UXGA 75Hz	93.750	75.000	1600	1200	P/P	<input type="checkbox"/>	RGB IN

Notes

- If the mode identification does not define the mode described on the chart above, adjust to the projection details.
- If the mode identification is carried out incorrectly, a normal display may be not obtained depending on the signal frequency.
- SXGA, UXGA signals can be projected since the projector has simplified compatibility with them. (However, letters and lines can be unequal or a part can be missing. Some signals may not be projected at all.)
- Some computers may have output modes which are not compatible with this projector. Check the compatibility of the connectors, signal levels, timing, and resolutions.

(Continued)

(Continued)

Signal assignment

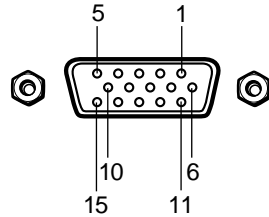

D-SUB 15 pin shrinking terminal

Input Signal

Video signal

Analog 0.7V(p-p) 75Ω

Horizontal synchronizing signal

TTL level (positive/negative polarity)

Vertical synchronizing signal

TTL level (positive/negative polarity)

Composite synchronizing signal

TTL level

Pin arrangements

Pin No.	
1	Video input (Red)
2	Video input (Green)
3	Video input (Blue)
4	N.C
5	GND
6	GND (Red)
7	GND (Green)
8	GND (Blue)
9	N.C
10	GND
11	GND
12	N.C
13	Horizontal synchronizing/ composite synchronizing signal
14	Vertical synchronizing signal
15	N.C



Discount-Merchant.com (800) 281-8860

THE TRUSTED SOURCE FOR PROJECTOR LAMPS AND ACCESSORIES

Others

(Continued)

RGB signal defaults

The following signals are factory set as defaults in each mode. However, some computers may have different timings than those in the chart. Make the necessary adjustments if the picture has flickers or is blurred.

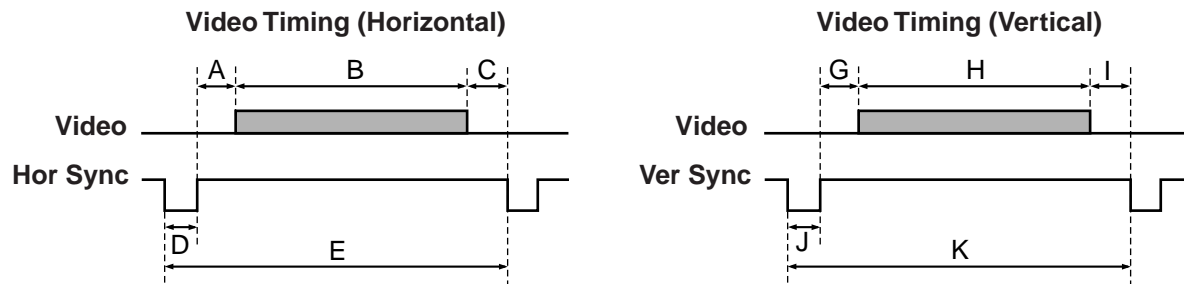

Timing chart

Mode	Resolution	A (Pixels)	B (Pixels)	C (Pixels)	D (Pixels)	E (Pixels)	fh (kHz)	fv (Hz)	Clock (MHz)	G (Lines)	H (Lines)	I (Lines)	J (Lines)	K (Lines)
NEC24k	640 x 400	85	640	59	64	848	24.83	56.42	21.053	25	400	7	8	440
TEXT70	640 x 350	50	640	14	96	800	31.47	70.09	25.175	59	350	38	2	449
TEXT70	640 x 400	50	640	14	96	800	31.47	70.09	25.175	34	400	13	2	449
TEXT85	640 x 350	96	640	32	64	832	37.86	85.08	31.500	60	350	32	3	445
TEXT85	640 x 400	96	640	32	64	832	37.86	85.08	31.500	41	400	1	3	445
VGA60	640 x 480	48	640	16	96	800	31.47	59.94	25.175	33	480	10	2	525
VGA72	640 x 480	128	640	24	40	832	37.86	72.81	31.500	28	480	9	3	520
VGA75	640 x 480	120	640	16	64	840	37.50	75.00	31.500	16	480	1	3	500
VGA85	640 x 480	80	640	56	56	832	43.27	85.01	36.000	25	480	1	3	509
MAC13	640 x 480	96	640	64	64	864	35.00	66.67	30.240	39	480	3	3	525
SVGA56	800 x 600	128	800	24	72	1024	35.16	56.25	36.000	22	600	1	2	625
SVGA60	800 x 600	88	800	40	128	1056	37.88	60.32	40.000	23	600	1	4	628
SVGA72	800 x 600	64	800	56	120	1040	48.08	72.19	50.000	23	600	37	6	666
SVGA75	800 x 600	160	800	16	80	1056	46.88	75.00	49.500	21	600	1	3	625
SVGA85	800 x 600	152	800	32	64	1048	53.67	85.06	56.250	27	600	1	3	631
MAC16	823 x 624	216	832	40	64	1152	49.72	74.55	57.283	39	632	1	3	667
XGA60	1024 x 768	160	1024	24	136	1344	48.363	60.004	65.000	29	768	3	6	806
XGA70	1024 x 768	144	1024	24	136	1328	56.476	70.069	75.000	29	768	3	6	806
XGA75	1024 x 768	176	1024	16	96	1312	60.023	75.029	78.750	28	768	1	3	800
XGA85	1024 x 768	208	1024	48	96	1376	68.677	84.997	94.500	36	768	1	3	808
MAC19	1024 x 768	180	1024	20	96	1320	60.197	74.872	73.200	30	768	3	3	804

Adjustments with RS-232C

Conditioning of the Projection Unit can also be done by a computer via the RS-232C, as well as by the remote control.

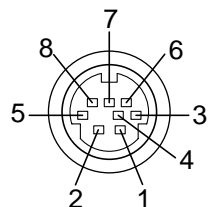

Mini DIN 8-pin
(Main Unit)

Pin No.	Signal	Meaning
1	RXD	Receiving data
2	CTS	Consent to send
3	DSR	Data set ready
4	GND	Signal ground
5	RTS	Request to send
6	N.C	No connection
7	TXD	Sending data
8	N.C	No connection

Interface format

1	Communication method	RS-232C 9600 bps, No parity, Data length: 8 bit, Stop bit: 1 bit
2	Communication format	STX (02h) Command (3Byte) ETX (03h) One command only can be used in one communication.
3	Data format	Command shall be composed of alphanumeric characters of ASCII description. Use only capital letters.
4	Return value	Acknowledge ACK (06h) Not Acknowledge NAK (15h)

Note

When commands are transmitted serially, keep more than 100 ms intervals between the commands.

Command list

Classification	Command	Meaning
NORMAL	POF	Power OFF
NORMAL	PON	Power ON
NORMAL	MOF	Video audio mute OFF
NORMAL	MON	Video audio mute ON
NORMAL	AON	Audio mute ON
NORMAL	DOF	Status display OFF
NORMAL	DON	Status display ON
NORMAL	FOF	Freeze OFF
NORMAL	FON	Freeze ON
NORMAL	IN1	Input (RGB)
NORMAL	IN2	Input (Video)
NORMAL	INS	Input (S-video)
RESIZE	RS0	Resize reset
RESIZE	RS1	Resize 1
RESIZE	RS2	Resize 2
RESIZE	RS3	Resize 3
RESIZE	RS4	Resize 4
ADJUST	ARS	Adjustment value reset
ADJUST	ARG	Adjustment value increase
ADJUST	ALF	Adjustment value decrease
ADJUST	AUP	Adjustment value increase
ADJUST	ADW	Adjustment value decrease
KEYSTONE	PKA	Keystone automatic adjustment
KEYSTONE	PKS	Keystone manual adjustment
Image	PAT	Panel automatic adjustment
Image	PVP	Vertical position adjustment
Image	PHP	Horizontal position adjustment
Image	PPH	Phase adjustment
Image	PCK	Clock adjustment

(Continued)

Others

(Continued)

Classification	Command	Meaning
Picture	VBR	Brightness adjustment
Picture	VCL	Color adjustment
Picture	VCN	Contrast adjustment
Picture	VSH	Sharp adjustment
Picture	VTN	Tint adjustment
Picture	VLB	Blue level adjustment
Picture	VLG	Green level adjustment
Picture	VLR	Red level adjustment
Audio	VOL	Volume adjustment
Audio	VTR	Treble adjustment
Audio	VBS	Bass adjustment
Default	LJP	Japanese display setting
Default	LEN	English display setting
Default	LFR	French display setting
Default	LGR	German display setting
Default	LIT	Italian display setting
Default	LSP	Spanish display setting
Default	LP0	Portuguese display setting
Default	PJ0	Floor-mounted front projection
Default	PJ1	Floor-mounted rear projection

Classification	Command	Meaning
Default	PJ2	Ceiling-mounted front projection
Default	PJ3	Ceiling-mounted rear projection
Default	KR0	RGB input mode (RGB)
Default	KR1	RGB input mode (Y/Pb/Pr)
Default	KV0	Video signal mode (Automatic)
Default	KV1	Video signal mode (60/NTSC/JAPAN)
Default	KV2	Video signal mode (60/NTSC/3.58)
Default	KV3	Video signal mode (60/NTSC/4.43)
Default	KV4	Video signal mode (60/PAL/3.58)
Default	KV5	Video signal mode (60/PAL/4.43)
Default	KV6	Video signal mode (50/NTSC/3.58)
Default	KV7	Video signal mode (50/NTSC/4.43)
Default	KV8	Video signal mode (50/PAL/3.58)
Default	KV9	Video signal mode (50/PAL/4.43)
Default	KVA	Video signal mode (50/SECAM/4.43)
Default	MO0	OSD mute OFF
Default	MO1	OSD mute ON
Save	DRS	Adjustment value preset
Save	DSV	Adjustment value saving



FixYourDLP.com

Sponsored by

Discount-Merchant.com (800) 281-8860

THE TRUSTED SOURCE FOR PROJECTOR LAMPS AND ACCESSORIES

Specifications

Main unit

Power requirements
AC 100 – 240V 50/60Hz

Power consumption
200W

Mass 3.7 Kg

Dimensions
318 x 87 x 232 (mm) (W/H/D)
(Including the projecting sections)

Ambient environment
Temperature : 0°C to 35°C
Humidity : 30% to 70% RH

Lamp UHP lamp 120W

Speaker 1W (monaural)

RGB INPUT
RGB signal : (D-sub 15-pin)
Audio: 1V(p-p), more than 22kΩ,
ø3.5mm stereo mini jack

VIDEO INPUT
S-video signal : Mini DIN 4-pin
Video signal : 1V(p-p), 75Ω
Audio : 1V(p-p), more than 22kΩ,
RCA pin jack

MONITOR OUTPUT
RGB signal : D-sub 15-pin
Audio : 1V(p-p), less than 2.2kΩ,
ø3.5mm stereo mini jack

CONTROL terminal
Mini DIN 8-pin (RS-232C)

Cabinet Material
ABS resin

Liquid crystal display

Projection system
3-panels transmission

Panel size
0.9 inches

Driving system
TFT active matrix

Picture elements
480,000 pixels (800 x 600 dots) x 3

Projection lens

Lens Zooming lens F = 1.8 – 2.1
f = 36 – 47mm

Focusing Manual operation

Zooming Manual operation

Accessories

Wireless remote control 1

R6 size battery 2

Power cord 2

Audio/Video cable 1 (3m)

Adapter for SCART socket 1

Lens cover 1

The design and specifications are subject to change without notice.

Trademarks

NEC, PC-98 series are trademarks of NEC Corporation.

IBM, DOS/V, VGA, SVGA, XGA, SXGA, UXGA are trademarks or registered trademarks of International Business Machines Corporation.

Macintosh is a registered trademark of Apple Computer, Inc.



Discount-Merchant.com (800) 281-8860

THE TRUSTED SOURCE FOR PROJECTOR LAMPS AND ACCESSORIES



Discount-Merchant.com (800) 281-8860
THE TRUSTED SOURCE FOR PROJECTOR LAMPS AND ACCESSORIES

TOSHIBA CORPORATION

Printed in Japan



Disclaimer

This user manual is provided as a free service by FixYourDLP.com. FixYourDLP is in no way responsible for the content of this manual, nor do we guarantee its accuracy. FixYourDLP does not make any claim of copyright and all copyrights remain the property of their respective owners.

About FixYourDLP.com

FixYourDLP.com (<http://www.fixyourdpl.com>) is the World's #1 resource for media product news, reviews, do-it-yourself guides, and manuals.

Informational Blog: <http://www.fixyourdpl.com>

Video Guides: <http://www.fixyourdpl.com/guides>

User Forums: <http://www.fixyourdpl.com/forum>

FixYourDLP's Fight Against Counterfeit Lamps:

<http://www.fixyourdpl.com/counterfeits>

Sponsors:

RecycleYourLamp.org – Free lamp recycling services for used lamps:

<http://www.recycleyourlamp.org>

Lamp Research - The trusted 3rd party lamp research company:

<http://www.lampresearch.com>

Discount-Merchant.com – The worlds largest lamp distributor:

<http://www.discount-merchant.com>



FixYourDLP.com

Sponsored by 