



# Disclaimer

This user manual is provided as a free service by FixYourDLP.com. FixYourDLP is in no way responsible for the content of this manual, nor do we guarantee its accuracy. FixYourDLP does not make any claim of copyright and all copyrights remain the property of their respective owners.

About FixYourDLP.com

FixYourDLP.com (<http://www.fixyourdlp.com>) is the World's #1 resource for media product news, reviews, do-it-yourself guides, and manuals.

Informational Blog: <http://www.fixyourdlp.com>

Video Guides: <http://www.fixyourdlp.com/guides>

User Forums: <http://www.fixyourdlp.com/forum>

FixYourDLP's Fight Against Counterfeit Lamps:

<http://www.fixyourdlp.com/counterfeits>

## Sponsors:

RecycleYourLamp.org – Free lamp recycling services for used lamps:

<http://www.recycleyourlamp.org>

Lamp Research - The trusted 3rd party lamp research company:

<http://www.lampresearch.com>

Discount-Merchant.com – The worlds largest lamp distributor:

<http://www.discount-merchant.com>



**FixYourDLP.com**

Sponsored by 



# LCD Projector User Guide

**XGA 350**

**XGA 338**

**SVGA 238**



**Discount-Merchant.com (800) 281-8860**

**THE TRUSTED SOURCE FOR PROJECTOR LAMPS AND ACCESSORIES**

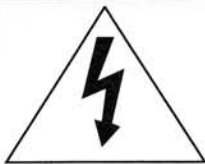

## CAUTION

RISK OF ELECTRIC SHOCK  
DO NOT OPEN



**CAUTION:** TO REDUCE THE RISK OF ELECTRIC SHOCK,  
DO NOT REMOVE COVER (OR BACK)  
NO USER-SERVICEABLE PARTS INSIDE  
REFER SERVICING TO QUALIFIED  
SERVICE PERSONNEL.



The lightning flash with arrowhead symbol, within an equilateral triangle, is intended to alert the user to the presence of uninsulated "dangerous voltage" within the product's enclosure that may be of sufficient magnitude to constitute a risk of electric shock.



The exclamation point within an equilateral triangle is intended to alert the user to the presence of important operating and maintenance (servicing) instructions in the literature accompanying the appliance.

## WARNING:

TO PREVENT FIRE OR SHOCK HAZARD, DO NOT EXPOSE THIS APPLIANCE TO RAIN OR MOISTURE.

## CAUTION:

TO PREVENT ELECTRIC SHOCK, DO NOT USE THIS (POLARIZED) PLUG WITH AN EXTENSION CORD, RECEPTACLE OR OTHER OUTLET UNLESS THE BLADES CAN BE FULLY INSERTED TO PREVENT BLADE EXPOSURE.

## NOTE:

SINCE THIS PROJECTOR IS PLUGGABLE EQUIPMENT, THE SOCKET-OUTLET SHALL BE INSTALLED NEAR THE EQUIPMENT AND SHALL BE EASILY ACCESSIBLE.

### WARNING

Use the attached specified power supply cord. If you use another power-supply cord, it may cause interference with radio and television reception.

Use the attached RGB cable, RS-232C cable with this equipment so as to keep interference within the limit

CC Class A device.

Sponsored by DM

This apparatus must be grounded.

The projector automatically shuts off when the lamp is used up in about 2,000 hours and cannot be used until lamp replacement.

**DO NOT LOOK DIRECTLY INTO THE LENS WHEN PROJECTOR IS IN THE POWER ON MODE.**

### When using the projector in Europe COMPLIANCE NOTICE

This LCD - Video Projector complies with the requirements of the EC Directive 89/336/EEC "EMC Directive" as amended by Directive 93/68/EEC and 73/23/EEC "Low Voltage Directive" as amended by Directive 93/68/EEC.

The electro-magnetic susceptibility has been chosen at a level that gains proper operation in residential areas, on business and light industrial premises and on small-scale enterprises, inside as well as outside of the buildings. All places of operation are characterised by their connection to the public low voltage power supply system.

### WARNING

Use the attached RGB cable or RS-232C cable with this equipment so as to keep interference within the limits of a EN55022 Class B and EN55013. Please follow WARNINGS instructions.

Important safeguards .....	4
Overview .....	6
Using the remote control .....	8
Battery installation .....	8
Installation .....	9
Basic connections .....	10
Projector + AV equipment .....	10
Projector + DVD player or HDTV decoder .....	10
Projector + Personal computer .....	11
For IBM PC or IBM PC compatibles .....	11
For Macintosh .....	11
Preparing the projector for operation .....	12
To operate projector power ON .....	13
Menu operation .....	15
Picture adjustment .....	18
Specification of RGB signals in each computer mode of the projector .....	20
Advanced feature for presentation .....	22
Expand .....	22
PinP (Picture in Picture) .....	22
Still .....	22
Mouse remote control .....	23
Lamp replacement .....	24
Maintenance .....	25
Troubleshooting .....	26
Indicators .....	27
Specifications .....	28
Kensington Lock .....	28
Connectors .....	29
Dimensional drawings .....	29
What's included in the box .....	29
Replacement part .....	29



**Discount-Merchant.com (800) 281-8860**  
**THE TRUSTED SOURCE FOR PROJECTOR LAMPS AND ACCESSORIES**

### Trademark, Registered trademark

Macintosh is registered trademark of Apple Computer Inc.

IBM and VGA are trademarks or registered trademarks of International Business Machines Corporation.

MicroSaver and Kensington are registered trademarks of Kensington Technology Group.

Other brand or product names are trademarks or registered trademarks of their respective holders.

# Important safeguards

Please read all these instructions regarding your LCD projector and retain them for future reference. Follow all warnings and instructions marked on the LCD projector.

1. **Read instructions**  
All the safety and operating instructions should be read before the appliance is operated.
2. **Retain instructions**  
The safety and operating instructions should be retained for future reference.
3. **Warnings**  
All warnings on the appliance and in the operating instructions should be adhered to.
4. **Instructions**  
All operating instructions must be followed.
5. **Cleaning**  
Unplug this projector from the wall outlet before cleaning it. Do not use liquid aerosol cleaners. Use a damp soft cloth for cleaning.
6. **Attachments and equipment**  
Never add any attachments and/or equipment without the approval of the manufacturer as such additions may result in the risk of fire, electric shock or other personal injury.
7. **Water and moisture**  
Do not use this projector near water or in contact with water.
8. **Accessories**  
Do not place this projector on an unstable cart, stand, tripod, bracket or table. Use only with a cart, stand, tripod bracket, or table recommended by the manufacturer or sold with the projector. Any mounting of the appliance should follow the manufacturer's instructions and should use a mounting accessory recommended by the manufacturer.



An appliance and cart combination should be moved with care. Quick stops, excessive force and uneven surfaces may cause the appliance and cart combination to overturn.

9. **Ventilation**  
Slots and openings in the cabinet are provided for ventilation, ensuring reliable operation of the projector and to protect it from overheating. Do not block these openings or allow them to be blocked by placing the projector on a bed, sofa, rug, or bookcase. Ensure that there is adequate ventilation and that the manufacturer's instructions have been adhered to.

10. **Power sources**  
This projector should be operated only from the type of power source indicated on the marking label. If you are not sure of the type of power, please consult your appliance dealer or local power company.
11. **Power-cord protection**  
Power-supply cords should be routed so that they are not likely to be walked on or pinched by items placed upon or against them. Pay particular attention to cords at plugs, convenience receptacles, and points where they exit from the appliance.
12. **Overloading**  
Do not overload wall outlets and extension cords as this can result in a fire or electric shock.
13. **Objects and liquids**  
Never push objects of any kind through openings of this projector as they may touch dangerous voltage points or short-out parts that could result in a fire or electric shock. Never spill liquid of any kind on the projector.
14. **Servicing**  
Do not attempt to service this projector yourself. Refer all servicing to qualified service personnel.
15. **Damage requiring service**  
Unplug this projector from the wall outlet and refer servicing to qualified service personnel under the following conditions:
  - (a) If the power-supply cord or plug is damaged.
  - (b) If liquid has been spilled, or objects have fallen into the projector.
  - (c) If the projector does not operate normally after you follow the operating instructions. Adjust only those controls that are covered by the operating instructions. An improper adjustment of other controls may result in damage and may often require extensive work by a qualified technician to restore the projector to its normal operation.
  - (d) If the projector has been exposed to rain or water.
  - (e) If the projector has been dropped or the cabinet has been damaged.
  - (f) If the projector exhibits a distinct change in performance - this indicates a need for service.
16. **Replacement parts**  
When replacement parts are required, be sure that the service technician has used replacement parts specified by the manufacturer or parts having the same characteristics as the original part. Unauthorized substitutions may result in fire, electric shock or other hazards.
17. **Safety check**  
Upon completion of any service or repair to this projector, ask the service technician to perform safety checks determining that the projector is in a safe operating condition.

**WARNING:****Unplug immediately if there is something wrong with your projector.**

Do not operate if smoke, strange noise or odor comes out of your projector. It might cause fire or electric shock. In this case, unplug immediately and contact your dealer.

**Never remove the cabinet.**

This projector contains high voltage circuitry. An inadvertent contact may result in an electric shock. Except as specifically explained in the Owner's Guide, do not attempt to service this product yourself. Please contact your dealer when you want to fix, adjust or inspect the projector.

**Do not modify this equipment.**

It can lead to fire or electric shock.

**If you break or drop the cabinet.**

Do not keep using this equipment if you break or drop it. Unplug the projector and contact your dealer for inspection. It may lead to fire if you keep using the equipment.

**Do not face the projector lens to the sun.**

It can lead to fire.

**Use correct voltage.**

If you use incorrect voltage, it can lead to fire.

**Do not place the projector on uneven surface.**

Place the projection on a leveled and stable surface only. Please do not place equipment on unstable surfaces.

Do not look into the lens when it is operating. It may hurt your eyes.

Never let children look into the lens when it is on.

**Do not turn off the main power abruptly or unplug the projector during operation.**

It can lead to lamp breakage, fire, electric shock or other trouble. It is best to wait for the fan to turn off before turning main power off.

**Place of installation**

For safety's sake, refrain from setting the projector at any place subjected to high temperature and high humidity. Please maintain an operating temperature, humidity, and altitude as specified below.

- Operating temperature: between +41°F (+5°C) and +95°F (+35°C)
- Operating humidity: between 30 and 90%
- Never put any heat-producing device under the projector so that the projector does not overheat.
- Do not attach the projector to a place that is unstable or subject to vibration.
- Do not install the projector near any equipment that produces a strong magnetic field. Also refrain from installing near the projector any cable carrying a large current.
- Place the projector on a solid, vibration free surface: otherwise it may fall, causing serious injury to a child or adult, and serious damage to the product.
- Do not stand the projector: it may fall, causing serious injury and damage to the projector.
- Place the projector within a slope of  $\pm 15^\circ$ . Slanting the projector more than  $\pm 15^\circ$  may cause trouble or explosion of the lamp.
- Do not place the projector near air-conditioning unit or heater to avoid hot air to the exhaust and ventilation hole of the projector.

**COMPLIANCE NOTICE OF FCC**

This equipment has been tested and found to comply with the limits for a Class A digital device, pursuant to Part 15 of the FCC Rules. These limits are designed to provide reasonable protection against harmful interference when the equipment is operated in a commercial environment. This equipment generates, uses, and can radiate radio frequency energy and, if not installed and used in accordance with the instruction manual, may cause harmful interference to radio communications. Operation of this equipment in a residential area is likely to cause harmful interference in which case the user will be required to correct the interference at his own expense.

This digital apparatus does not exceed the Class A limits for radio noise emissions from digital apparatus as set out in the interference-causing equipment standard entitled "Digital Apparatus", ICES-003 of the Department of Communications.

Changes or modifications not expressly approved by Polaroid could void the user's authority to operate this equipment.

**COMPLIANCE NOTICE OF INDUSTRY CANADA**

This Class A digital apparatus complies with Canadian ICES-003.

# Overview

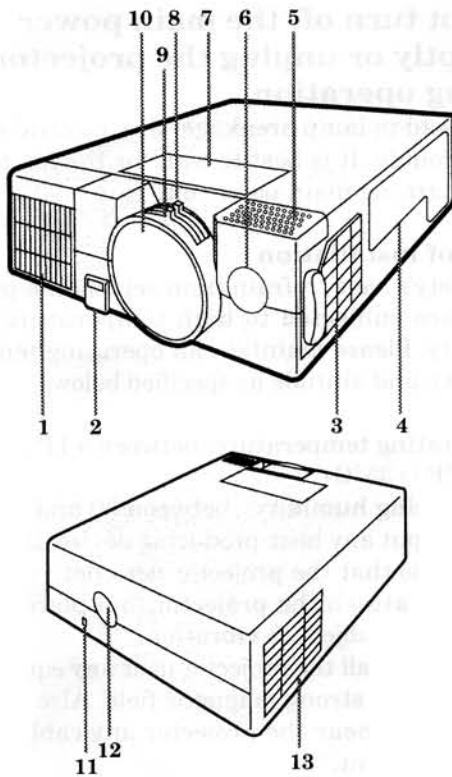

- 1 Air inlet grill (Front)
- 2 Front height adjuster button
- 3 Air inlet grill (Side)
- 4 Terminal board
- 5 Speaker
- 6 Remote control sensor (Front)
- 7 Control panel
- 8 Zoom ring
- 9 Focus ring
- 10 Lens
- 11 Kensington Security Lock Standard connector
- 12 Remote control sensor (Rear)
- 13 Air outlet grill

## Control panel

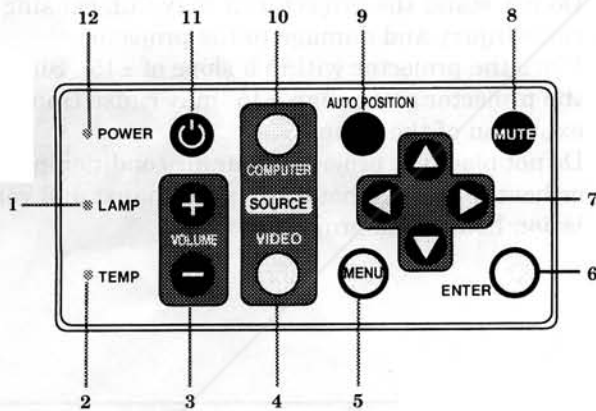

- 1 LAMP indicator
- 2 TEMP (temperature) indicator
- 3 +, - (VOLUME) buttons
- 4 VIDEO button
- 5 MENU button
- 6 ENTER button
- 7 Direction buttons
- 8 MUTE button
- 9 AUTO POSITION button
- 10 COMPUTER button
- 11 POWER button
- 12 POWER indicator

## Terminal board

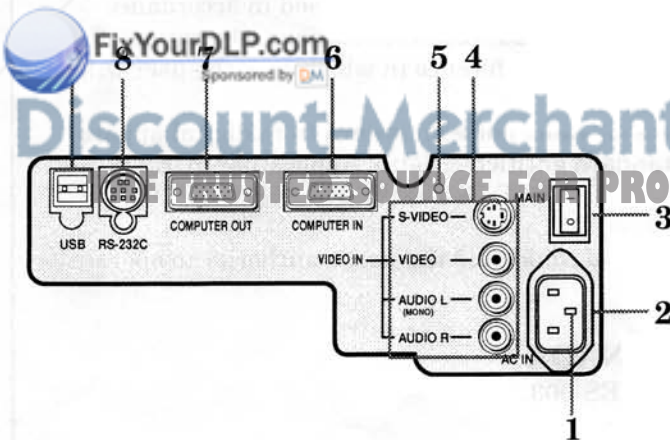

- 1 Ground terminal
- 2 Power jack
- 3 Main power  
- : ON  
O : OFF
- 4 Video/audio input terminals
- 5 Reset button
- 6 COMPUTER IN terminal (D-SUB mini 15P)
- 7 COMPUTER OUT terminal (D-SUB mini 15P)
- 8 RS-232C (DIN 8P) terminal
- 9 USB terminal

## Bottom side

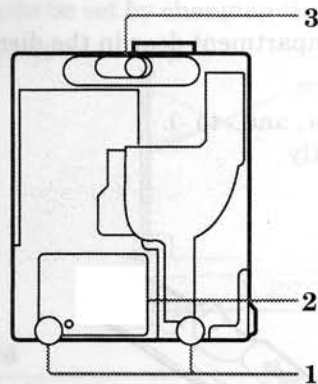

- 1 Adjustment foot (right and left)
- 2 Lamp cover
- 3 Adjustment foot (up and down)

### Caution:

Do not replace the lamp right after using the projector. The lamp is very hot.

## Remote control

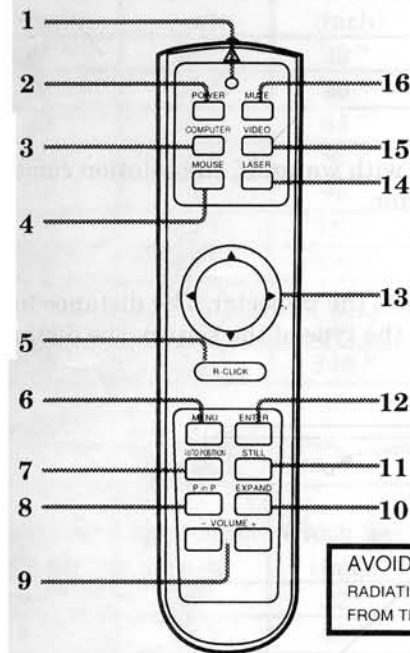

- 1 Transmitter indicator
- 2 POWER button
- 3 COMPUTER button
- 4 MOUSE button
- 5 Right click button (For mouse)
- 6 MENU button
- 7 AUTO POSITION button
- 8 PinP button (For 350 only)
- 9 +, - (VOLUME) buttons
- 10 EXPAND button
- 11 STILL button
- 12 ENTER button
- 13 Mouse pointer / Direction button
- 14 LASER button
- 15 VIDEO button
- 16 MUTE button
- 17 Laser aperture
- 18 Left click button (For mouse)

- When pressing MOUSE button, it illuminates and Direction button work as the mouse pointer. Press the MOUSE button or MENU button to set off. (Direction button work as Direction button.)
- Pressing LASER button emits the laser beam about 1 minute. Release LASER button and press it again if you wish to emits the laser beam.

AVOID EXPOSURE -LASER  
RADIATION IS EMITTED  
FROM THIS APERTURE.



### About laser beam

This remote control is class 2 (max. output 1 mW laser diode 640 - 660 nm) laser equipment.

Beam Divergence : 3 m distance about 5.0 mm x 3.0 mm (±1.5 mm)

### CAUTION

LASER RADIATION  
DO NOT STARE INTO BEAM



WAVE LENGTH : 640 - 660 nm  
MAX OUTPUT : 1m W  
CLASS 2 LASER PRODUCT  
IEC 60825-1:1993+A1:1997

### CAUTION :

- Pressing the LASER button provided remote control emits laser beam. Do not look into the beam light directly. Do not point the laser beam at people. Looking the laser beam directly may damage eyesight.
- Use of controls or adjustments or procedures other than those specified herein may result in hazardous radiation exposure.



# Using the remote control

## Battery installation

Use two AAA size batteries.

1. Remove the back cover of the remote control by pushing the battery compartment door in the direction of the arrow.
2. Load the batteries making sure that they are positioned correctly (+ to +, and - to -).
  - Load the batteries from - spring side, and make sure to set them tightly.
3. Replace the back cover.

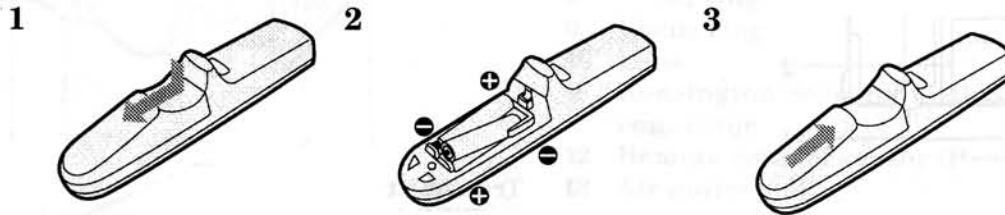

### Important:

- Do not combine a new battery with an old one.
- Load batteries in the correct position.
- Do not heat, take apart, or throw batteries into fire.
- Do not try to recharge batteries. Do not use rechargeable batteries.
- If the solution of batteries comes in contact with your skin or clothes, rinse with water. If the solution comes in contact with your eyes, rinse them with water and then consult your doctor.

## Operation area

The range for operation is about 10 m (33 feet) when the remote control points to the projector. The distance to the screen back to the projector must be less than 6 m (20 feet). Depending on the type of the screen, the distance is different.

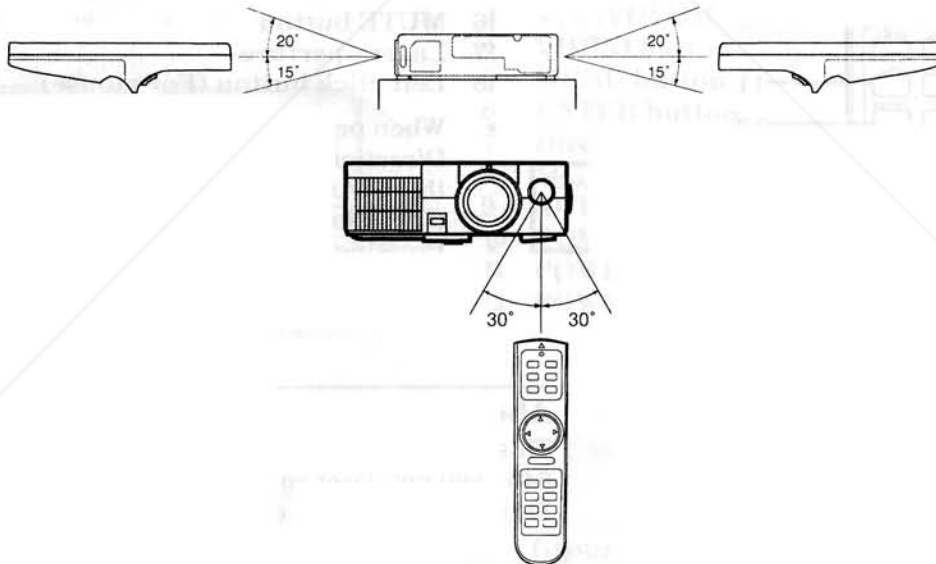

### Important:

Do not point the remote control directly at the projector or fluorescent light. Also keep the distance of more than 2 m between the remote control sensor and fluorescent lamp on the remote control may not work correctly.

**Discount-Merchant.com (800) 281-8860**  
THE TRUSTED SOURCE FOR PROJECTOR LAMPS AND ACCESSORIES

# Installation

## Orientation of the projector

Picture size can be set by changing the distance between the screen and the projector.

### Front projection

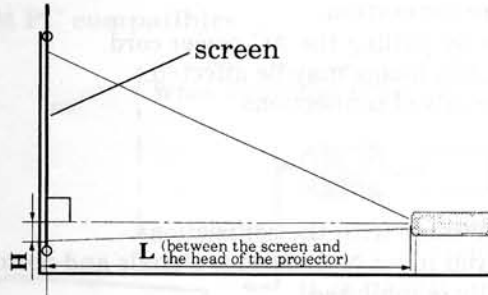

To find the approximate distance between the projector and screen:

Multiply the width of the screen  $\times 1.7$  ( $\times 1.8$  for 238) / min. , Multiply the width of the screen  $\times 2.4$  ( $\times 3.1$  for 238) / max.

- Refer to the chart for recommended distances in maximum zoom and minimum zoom.

### For 338 / 350

Screen			Distance from screen (L) / (approximate)				Height projected image (H)	
Diagonal size (inch)	Height inches (inch)	Width feet (inch)	Maximum zoom (WIDE)		Minimum zoom (TELE)		(cm)	(inch)
			(cm)	(inch)	(cm)	(inch)		
40 "	24 "	32 "	140	55 "	184	72 "	6.1	2.4 "
60 "	36 "	48 "	213	84 "	279	110 "	9.1	3.6 "
80 "	48 "	64 "	286	113 "	374	147 "	12.2	4.8 "
100 "	60 "	80 "	360	142 "	469	185 "	15.2	6.0 "
120 "	72 "	96 "	433	171 "	564	222 "	18.3	7.2 "
140 "	84 "	112 "	506	199 "	659	259 "	21.3	8.4 "
160 "	96 "	128 "	579	228 "	754	297 "	24.4	9.6 "
180 "	108 "	144 "	652	257 "	849	334 "	27.4	10.8 "
200 "	120 "	160 "	725	285 "	944	372 "	30.5	12.0 "
300 "	180 "	240 "	1070	421 "	1393	548 "	45.7	18.0 "

### For 238

Screen			Distance from screen (L) / (approximate)				Height projected image (H)	
Diagonal size (inch)	Height inches (inch)	Width feet (inch)	Maximum zoom (WIDE)		Minimum zoom (TELE)		(cm)	(inch)
			(cm)	(inch)	(cm)	(inch)		
40 "	24 "	32 "	153	60 "	247	97 "	6.1	2.4 "
60 "	36 "	48 "	233	92 "	374	147 "	9.1	3.6 "
80 "	48 "	64 "	312	123 "	501	197 "	12.2	4.8 "
100 "	60 "	80 "	392	154 "	628	247 "	15.2	6.0 "
120 "	72 "	96 "	472	186 "	755	297 "	18.3	7.2 "
140 "	84 "	112 "	551	217 "	882	347 "	21.3	8.4 "
160 "	96 "	128 "	631	248 "	1009	397 "	24.4	9.6 "
180 "	108 "	144 "	711	280 "	1135	447 "	27.4	10.8 "
200 "	120 "	160 "	790	311 "	1261	496 "	30.5	12.0 "
300 "	180 "	240 "	1166	459 "	1861	733 "	45.7	18.0 "

- The above numbers are approximate, and may be slightly different from the actual measurements.

### Wall mount, Rear projection

Specialist for installation. For more details, contact your dealer.

### Caution:

- Placing the projector on a carpet reduces ventilation from the fan at the bottom and might cause problems. Place a hard board or similar item under the projector to facilitate ventilation of the unit.
- Place the projector more than 50 cm (20 inches) from the wall to prevent blocking the intake, exhaust slots and ventilation of this projector because hot air comes out of it.

- Do not use the projector under the following circumstances, which may cause fire or electric shock.

- in a dusty or humid place
- while the projector is lying sideways or upside down
- near a heater
- in a kitchen or oily, smoky or damp place
- in direct sunlight
- with high temperature, such as the closed car
- where the temperature is lower than 41 °F or higher than 95 °F

### Important:

- Do not add stress on the lens, as this may cause damage.

## Basic connections

This projector can be connected to equipment such as PC, VCRs, video cameras and DVD players.

### Important:

- Make sure that your equipment is turned off before connection.
- Plug in firmly and unplug by holding the plug, not by pulling the AC power cord.
- If connected units are set too close to one another, the image may be affected.
- Refer to the user manual of each component for details of connections.

### Projector + AV equipment

#### Important:

- Match the color of video and audio plugs on the AV cable with the connections.
- S-video signals take priority over video signals. If you input both S-video signals and normal video signals at the same time, the normal video input automatically is inhibited.

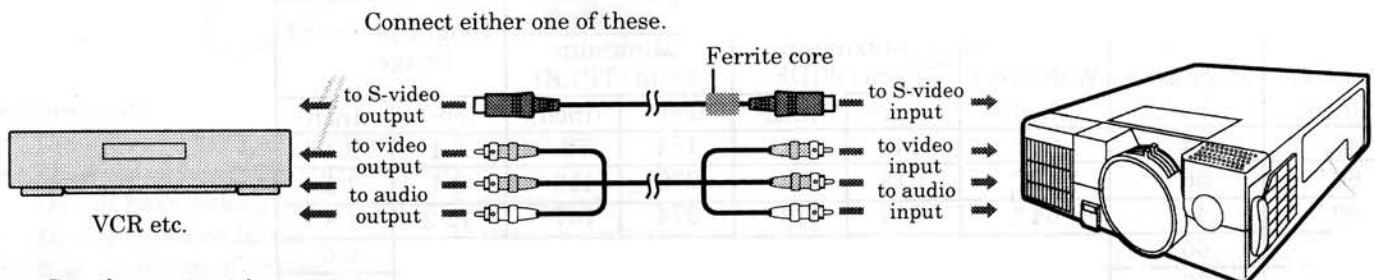

- Speaker output is mono.
- Select AUDIO MODE 2 to hear and to sound for the VIDEO. (Refer to page 16).
- When connecting audio output of equipment which audio output is mono, connect to audio input L terminal.

### Projector + DVD player or HDTV decoder

Some DVD players have output terminal for 3 line fitting (Y, C<sub>B</sub>, C<sub>R</sub>). When connecting them to the projector, connect to COMPUTER IN of the projector. In this case, set "Y, C<sub>B</sub>, C<sub>R</sub>" for COMPUTER INPUT setting in SIGNAL menu.

DVD player generally has SDTV system component video output (Y, C<sub>B</sub>, C<sub>R</sub>) terminals. HDTV decoder has HDTV system component video output (Y, P<sub>B</sub>, P<sub>R</sub>) terminals. When connecting the projector with DVD player or HDTV decoder, the signal circuit automatically applied to either of them. In this case, the COMPUTER INPUT in the SIGNAL menu becomes [Y, C<sub>B</sub>, C<sub>R</sub>/Y, P<sub>B</sub>, P<sub>R</sub>].

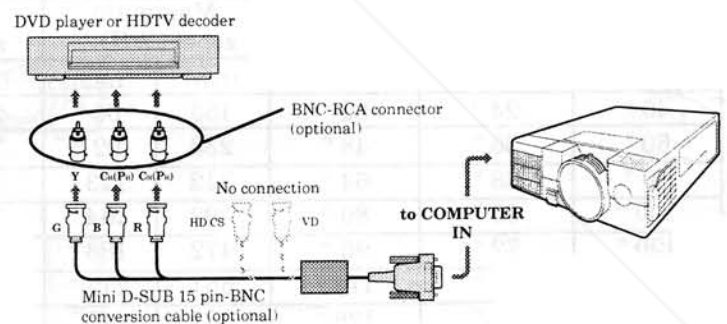

- Y, P<sub>B</sub>, P<sub>R</sub> is an example of the terminal names for a HDTV decoder.
- The terminal name is different depending on the connected equipment.
- Use mini D-SUB 15 pin-BNC conversion cable for connection.
- Some DVD players may not project the image correctly.
- When connecting with HDTV equipment which has R, G, B output, set RGB for the COMPUTER INPUT in the SIGNAL menu.
- Change the setting in the SIGNAL menu, when 525p signal is inputted. (Refer to page 20, 21).

FixYourDevice.com

Discount-Merchant.com (800) 281-8860

THE TRUSTED SOURCE FOR PROJECTOR LAMPS AND ACCESSORIES

# Projector + Personal computer

## Connection

### For IBM PC or IBM PC compatibles

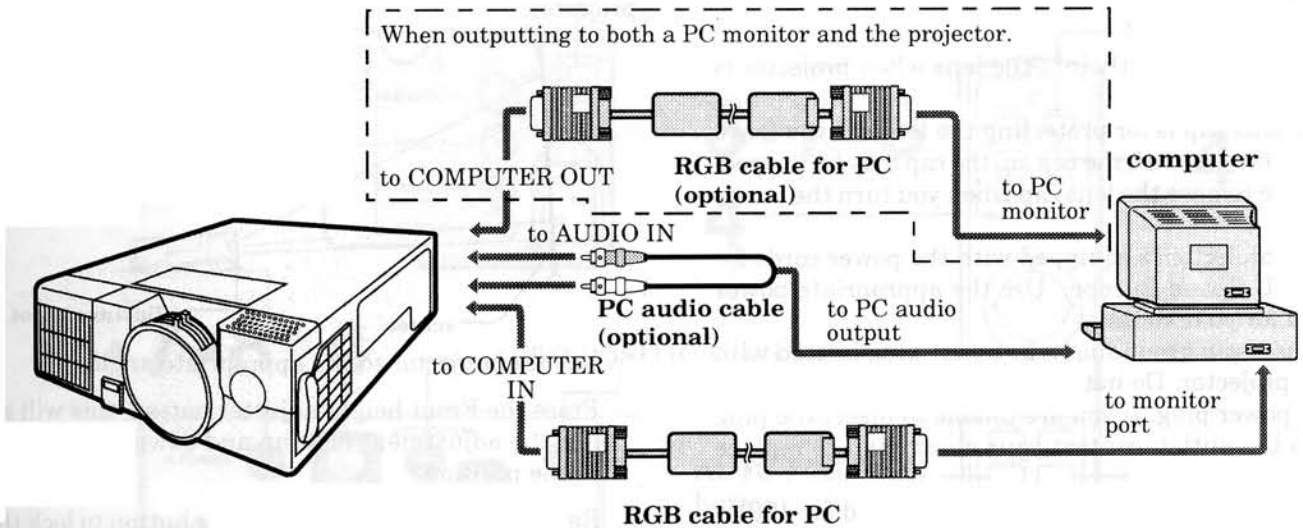

### For Macintosh

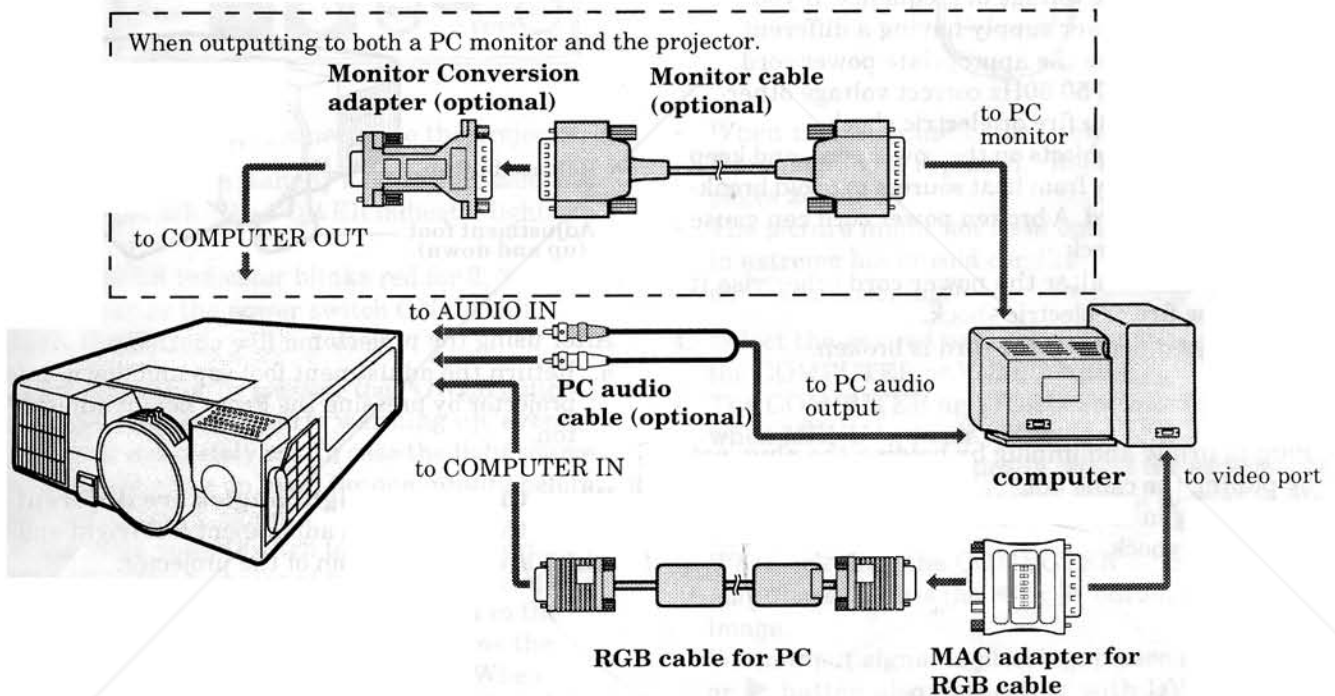

### Important:

- Connectors or analog RGB output adapters may be necessary depending on the PC connected to this projector. Please contact your dealer.
- The audio input for this projector is a stereo pin jack. (Speaker output is mono.) Please check the available terminals for the audio input terminal of the PC. Some personal computer may not have the audio output terminal.
- Select AUDIO MODE 1 to hear and to sound for the COMPUTER. (Refer to page 16).
- When connecting audio output of a personal computer which audio output is mono, connect to the audio input L terminal.

## THE TRUSTED SOURCE FOR PROJECTOR LAMPS AND ACCESSORIES

### For using Macintosh

- A monitor output adapter is necessary for a Macintosh if it has no video port. Please contact your dealer.
- If you use the MAC adapter for RGB cable provided, set the dip switch to the appropriate position.

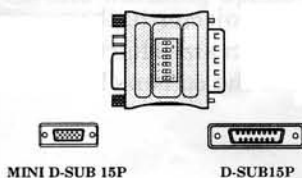

Display mode	Resolution	Dip switch					
		1	2	3	4	5	6
13 inch	640 × 480	ON	ON	OFF	OFF	OFF	OFF
16 inch	832 × 624	OFF	ON	ON	OFF	OFF	OFF
19 inch	1024 × 768	OFF	ON	ON	OFF	OFF	OFF
21 inch	1152 × 870	ON	ON	ON	ON	OFF	OFF

(238)  
(338 / 350)

# Preparing the projector for operation

## Getting ready for projection

1. Connect the power cord provided to the projector.
2. Connect the power cord to the wall power outlet.
3. Remove the lens cap.

### Warning:

- Do not look directly into the lens when projector is "ON".
- The lens cap is for protecting the lens. If you leave the power on with the cap on, the cap may be warped. Please remove the lens cap when you turn the power on.
- This projector is equipped with the power cords for both U.S. and Europe. Use the appropriate power cord for your country.
- A three-pin grounding type power plug is used with the projector. Do not remove the grounding pin on the power plug. If you are unable to insert the plug into the outlet, contact your electrician to replace your A/C outlet.
- The supplied power cord for U.S. is used for 120V only. Never connect to any outlet or power supply having a different voltage or frequency. If you connect to the power supply having a different voltage, please use the appropriate power cord.
- Use 100-240V AC 50/60Hz correct voltage otherwise it may lead to fire or electric shock.
- Do not place any objects on the power cord, and keep the projector away from heat sources to avoid breaking the power cord. A broken power cord can cause fire or electric shock.
- Do not revise or alter the power cord otherwise it may cause fire or electric shock. Contact your dealer if the cord is broken.

### Caution:

- Plug in firmly and unplug by holding the plug, not by pulling the cable out.
- Do not plug in or out with wet hands. It may cause an electric shock.

## Adjusting the angle of projection

For the best result, project onto a flat screen with a 90 degree angle to the floor. If necessary, tilt the projector by adjusting two foot adjustments on the bottom of the projector.

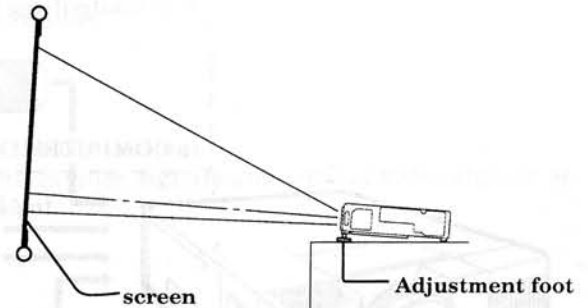

1. Lift the projector to the appropriate angle.
2. Press the Front height adjuster button, this will allow the adjustment foot (up and down) to slide out to the position.
3. Release the Front height adjuster button to lock the feet in that position.

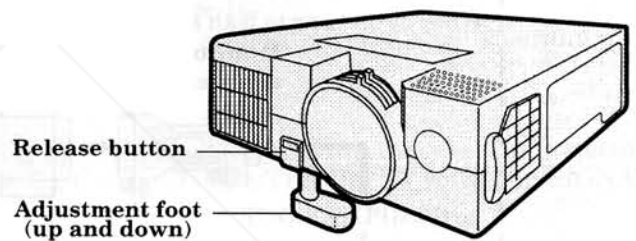

After using the projector

4. Return the adjustment foot (up and down) into the projector by pressing the Front height adjuster button.

### When the left and right angles are different

Adjust the angles with adjustment feet (right and left), which are on the bottom of the projector.

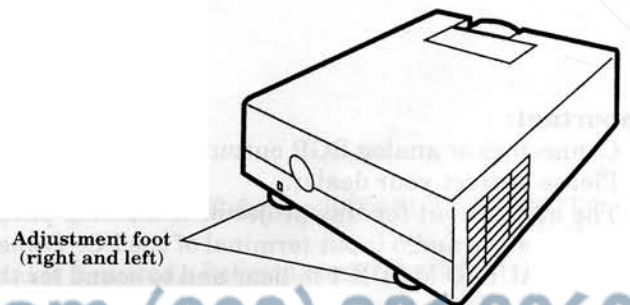

### Important:

- Screen on a flat wall with a 90° angle to the floor.
- Align projector to produce a full screen display as illustrated on page 9.
- The distance from the projector to the screen must be compatible with screen size chart on page 9. Note the distance from the screen chart.

# To operate projector power ON

2 • 9

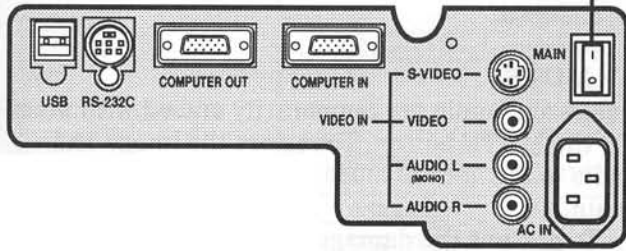

3 • 7 • 8 4

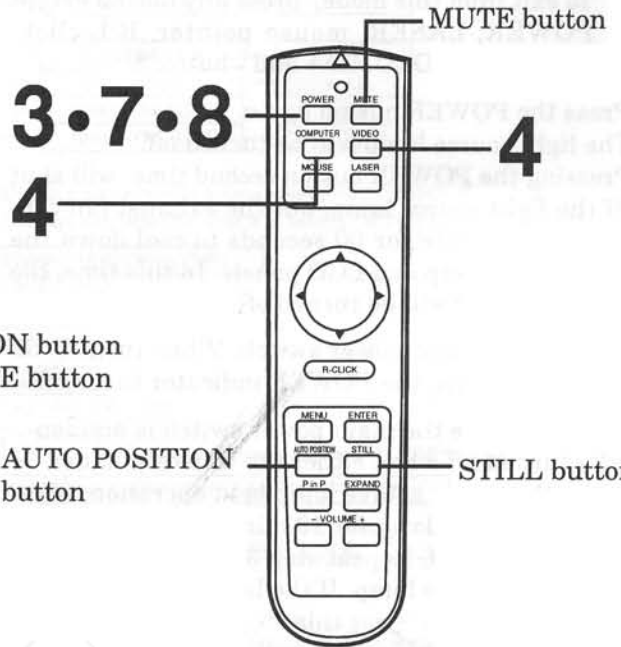
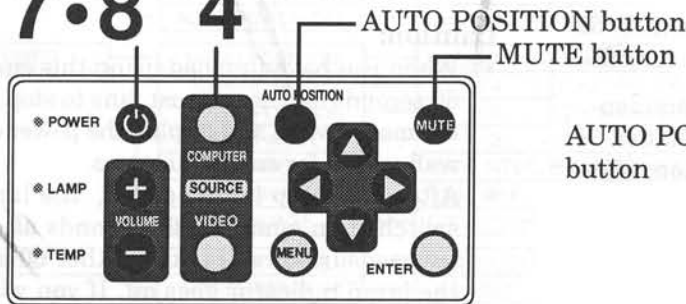

1. Turn on the equipment connected to the projector.
2. Put the projector into standby mode by pressing the main power switch. The POWER indicator lights up red.
  - The POWER indicator blinks red for 2, 3 seconds after the power switch ON. In this time, the buttons will not work.
3. Turn the projector on by pressing the POWER button. The light source lamp starts warming up, eventually turning completely on. In case the light source lamp does not come on, wait for one minute before switching power on again.
  - If the main power switch to the unit is turned off within two minutes of turning off the light source lamp, power will not be applied to the lamp for one minute when the next time the main unit power switch is turned on. When this happens, the indicator lamp will blink for one minute.

- When the lamp indicator is blinking red, the the lamp should be replaced. Replace the lamp. See pages 24 and 27.
  - The picture might not be of optimum performance in extreme hot or cold conditions. (The projector is not malfunctioning.)
4. Select the desired external input source by using the COMPUTER or VIDEO button.
    - The COMPUTER or VIDEO buttons do not work when MENU is displayed.
    - The projector automatically selects the appropriate signal format. The selected signal format is displayed on the screen.
    - When selecting the COMPUTER input, the image may flicker. Press the ◀ or ▶ button to adjust the image.
    - When input signal is jittering, please adjust by ◀ or ▶ button also connecting with DVD player or MUSE decoder etc.
    - When supplying unstable signal like Still or Reverse play with VCR, "NO SIGNAL" may appear on the screen. In this case, you may avoid this issue by selecting the right color format like NTSC, PAL in OPTION menu.
  5. Adjust the image size with the zoom ring by turning it.
  6. Adjust the focus with the focus ring by turning it.

Indicator	LAMP	POWER
Stand-by	-	Red
When light source lamp is on	Green	Green
Light source lamp held off temporarily	-	Red

### Important:

- A darkened image may be seen right after pressing the POWER button due to warming up of this projector. While warming up, no other commands can be accepted.

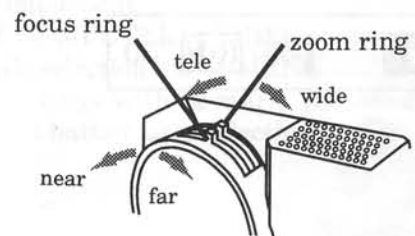

## To operate projector power ON (Continue)

### Turning off the projector

7. Press the POWER button.  
The message "POWER OFF? YES : PRESS AGAIN" appears on the screen.
  - To exit from this mode, press any button except POWER, LASER, mouse pointer, R/L-click, STILL and VOLUME + and - buttons.
8. Press the POWER button again.  
The light source lamp will be turned off.  
Pressing the POWER button second time will shut off the light source lamp, but the exhaust fan continues to operate for 60 seconds to cool down the light source lamp and LCD panels. In this time, the lamp indicator will be turned off.
9. Turn off the main power switch. When turning off the main switch, the POWER indicator turns off.
  - In cases where the main power switch is accidentally turned off when either the intake/exhaust fan or the power source lamp is in operation, allow the unit to cool down for 10 minutes with the power turned off. Repeat step 3 when turning on the power source lamp. If the lamp does not turn on immediately, repeat this step two or three times. Replace the lamp if it should still fail to turn on.

### AUTO POSITION button

When the source is selected to COMPUTER and the image is not in the right place, set the screen to the brightest display possible, then press the AUTO POSITION button on the remote control. If the image is still not in the right place.

- Set screen to the brightest display as possible (e.g., full-screen display of the "Trash" window) before deploying the automatic adjustment function.
- If the screen saver is running, turn off the screen saver before using the automatic adjustment button.

### The sound from the speaker

The sound from the speaker is mono.

- When inputting mono sound, connect to AUDIO L terminal.
- The output sound is selected by changing the setting of AUDIO MODE in the FEATURE menu. See page 16 for details.

### The volume from the speaker

Press the volume + or - button to change the volume from the speaker.

The volume control bar will appear on the screen.

- The volume control bar will disappear about 4 seconds after releasing the volume buttons.
- The volume buttons do not work when MENU selection bar or MENU is displayed.
- The volume from the audio output terminals are not changed.

### AV MUTE

Image and audio are temporarily erased with pressing the MUTE button. To restore the image and audio to the normal mode, press the MUTE button again.

- To prevent the damage of the LCD, the image and audio will be restored automatically to the normal mode, 10 minutes after setting the AV MUTE mode.

### Caution:

- When you have finished using this equipment, wait 60 seconds for the exhaust fans to stop. Then turn off the main switch and unplug the power cable from the wall outlet, for safety purposes.
- After the lamp is turned off, the lamp cannot be switched on again for 60 seconds as a precautionary measure. It will take another 60 seconds before the lamp indicator goes off. If you wish to turn on the projector again, wait until the indicator is off then press the POWER button.
- The exhaust fan rotates faster when the temperature around the projector rises.
- When the temperature around the projector becomes too high, the sign "TEMP!!" blinks red on the screen. If the temperature stays too high, the lamp will be shut off automatically.

**The projector automatically shuts off when the lamp is used up in about 2000 hours. You must replace the lamp.**



# Menu operation

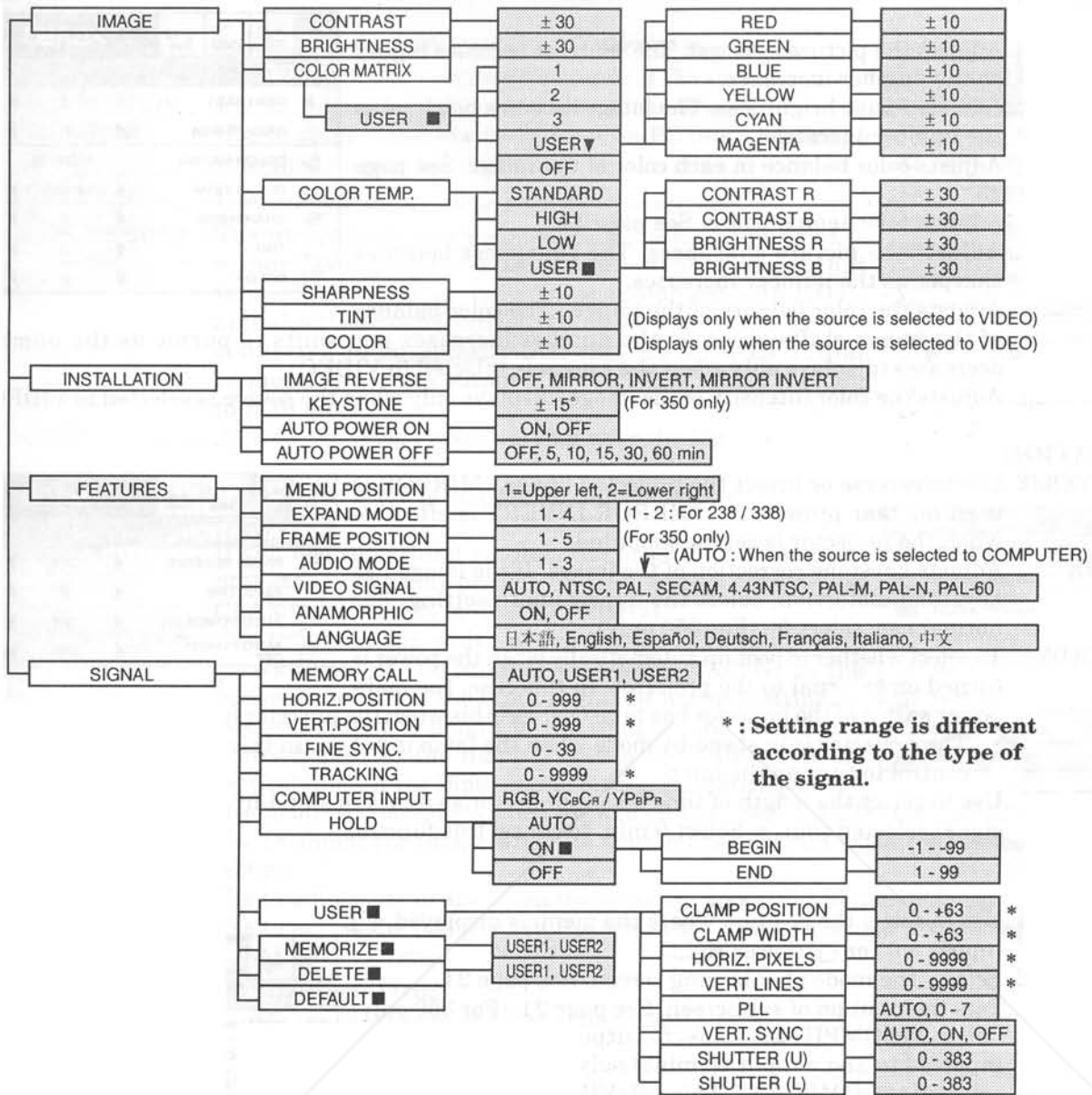

## Basic operation

Several settings can be adjusted using Menu.

EXAMPLE: Auto power off time setting

1. Press the MENU button.

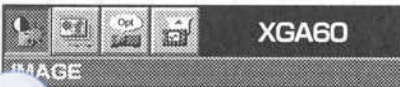

2. Press the left or right button to select the INSTALLATION menu.

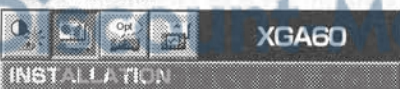

3. Press the ENTER button (or down button).

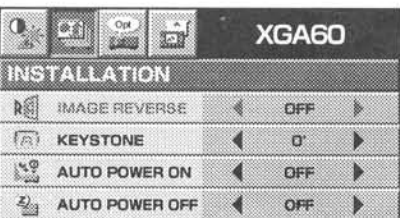

4. Press the up or down button to select AUTO POWER OFF.

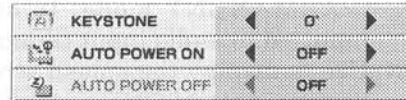

5. Press the left or right button to adjust auto power off time.

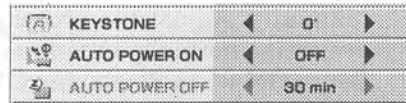

6. Exit the menu system by pressing the MENU button several times.

If the menu operation is not working, press the RESET button on the terminal board using the suitable implement

- If the COMPUTER or VIDEO button is pressed, the MENU selection bar or MENU will disappear.
- The settings with ■ mark, you should press the ENTER button after selecting.



## Menu operation (continued)

### ① IMAGE

- CONTRAST** ..... Adjusts the picture contrast. The contrast becomes higher as the number increases.
- BRIGHTNESS** .... Adjusts image brightness. The image becomes brighter as the number increases.
- COLOR MATRIX** ..... Adjusts color balance in each color of the image. See page 18.
- COLOR TEMP**.... Adjusts color temperature. See page 18.
- SHARPNESS** ..... Adjusts the picture sharpness. The sharpness becomes sharper as the number increases.
- TINT** ..... Adjusts the color balance of the image. The color balance of the image shifts green as the number increases and shifts to purple as the number decreases (displays only when the source is selected to VIDEO).
- COLOR**..... Adjusts the color intensity of the image (displays only when the source is selected to VIDEO).

XGA60	
<b>IMAGE</b>	
CONTRAST	◀ 0 ▶
BRIGHTNESS	◀ 0 ▶
COLOR MATRIX	USER ■
COLOR TEMP.	◀ STANDARD ▶
SHARPNESS	◀ 0 ▶
TINT	◀ 0 ▶
COLOR	◀ 0 ▶

### ② INSTALLATION

- IMAGE REVERSE** Use to reverse or invert the projected image. MIRROR is used for rear projection. MIRROR INVERT is effective when the projector is ceiling-mounted.
- KEYSTONE** ..... Adjusts keystone correction of the image. If the image has keystone distortion, select the approximate setting. For normal use, select 0°. (For 350 only)
- AUTO POWER ON** .... To select whether to boot up automatically when the power is turned on external to the projector. In this case, the main power switch of the projector has to be ON. Set this when the projector is hanging on the ceiling.
- The projector is in stand-by mode when the lamp is not on. In this case, use the remote control to turn on the lamp.
- AUTO POWER OFF** .. Use to select the length of time before projector switches to stand-by when there is no input signal selected source. Select 0 min. to cancel this function.

XGA60	
<b>INSTALLATION</b>	
IMAGE REVERSE	◀ OFF ▶
KEYSTONE	◀ 0° ▶
AUTO POWER ON	◀ OFF ▶
AUTO POWER OFF	◀ OFF ▶

### ③ FEATURES

- MENU POSITION**. Use to select the position where the menu is displayed,  (upper left) or  (lower right).
- EXPAND MODE** Selects the mode of enlarging screen. See page 21.
- FRAME POSI.** .... Sets the position of sub screen. See page 21. (For 350 only)
- AUDIO MODE** ..... Select 1 (COMPUTER mode) to output the sound which is inputted to audio input terminal only when the source is selected to COMPUTER. Select 2 (VIDEO mode) to output the sound which is inputted to audio input terminal only when the source is selected to VIDEO. Select 3 (PERMANENT mode) to output the sound which is inputted to audio input terminal all time.
- SPLASH SCREEN**. Use to display the splash screen on the screen when the power is turned ON.
- VIDEO SIGNAL** . When AUTO is set, the appropriate video format is automatically selected according to the input signal. If the image does not appear correctly, select the desired video format manually. Adjust the projector to the appropriate format when the projector either is not projecting normally in auto mode or is projecting PAL-M/PAL-N signals.
- ANAMORPHIC**. Set to ON when displaying DVD discs which are recorded as squeezed images (in right and left direction).
- LANGUAGE** ..... Use to select the language for the projector display such as menu. (日本語 / English / Español / Deutsch / Français / Italiano / 中文)

XGA60	
<b>FEATURE</b>	
MENU POSITION	◀ 1 <input type="checkbox"/> ▶
EXPAND MODE	◀ 1 <input type="checkbox"/> ▶
FRAME POSI.	◀ 1 <input type="checkbox"/> ▶
AUDIO MODE	◀ 2 ▶
VIDEO SIGNAL	◀ AUTO ▶
ANAMORPHIC	◀ OFF ▶
LANGUAGE	◀ English ▶



Discount-Merchant.com (800) 281-8860

THE TRUSTED SOURCE FOR PROJECTOR LAMPS AND ACCESSORIES

#### ④ SIGNAL

MEMORY CALL ..... Use to select AUTO, USER 1 or USER 2. See below.  
 HORIZ. POSITION .... Use to adjust the horizontal position of the image.  
 VERT. POSITION .... Use to adjust the vertical position of the image.  
 FINE SYNC. .... Use to synchronize the projector with PC input signals so that the image is not blurred.

TRACKING ..... Use to avoid image noise such as wide stripes.  
 COMPUTER INPUT ... The unit adjusts itself automatically when connected to either DVD players with a component video output terminal (Y, C<sub>B</sub>, C<sub>R</sub> or Y, P<sub>B</sub>, P<sub>R</sub>) or equipment with HDTV signal output capabilities. In cases where the unit is connected to equipment that include an RGB output terminal and which output HDTV signals, adjust the unit to RGB mode.

HOLD ..... Adjusts the image when curving near the top.

XGA60		
SIGNAL		
MEMORY CALL	◀	AUTO ▶
HORIZ. POSITION	◀	208 ▶
VERT. POSITION	◀	22 ▶
FINE SYNC.	◀	24 ▶
TRACKING	◀	1056 ▶
COMPUTER INPUT	◀	RGB ▶
HOLD	◀	AUTO ▶
USER	MEMORIZE	DELETE
■	■	■

#### ⑤ SIGNAL - USER (Normally, there is no need for adjustments.)

CLAMP POSITION/  
 CLAMP WIDTH ..... If you use something similar, the brighter colors of the projected image may become blurred. In this case, adjust CLAMP POSITION or CLAMP WIDTH.

HORIZ.PIXELS .. Use to adjust the width of the image. The image size grows wider as the number increases. (Adjust to the horizontal pixels of the input signal for normal setting.)

VERT.LINES ..... Use to adjust the height of the image. The image size grows higher as the number increases. (Adjust to the vertical lines of the input signal for normal setting.)

PLL ..... Use to adjust the image when skewed on top. Select AUTO for normal setting.

VERT.SYNC. .... Use to adjust the image when its motion does not run smoothly. Select AUTO for normal setting.

SHUTTER(U) ..... Use to adjust the image when the noise etc. appears on top part of image.

SHUTTER(L) ..... Use to adjust the image when the noise etc. appears on bottom part of image.

SIGNAL - USER		
CLAMP POSITION	◀	0 ▶
CLAMP WIDTH	◀	+5 ▶
HORIZ. PIXELS	◀	800 ▶
VERT. LINES	◀	600 ▶
PLL	◀	AUTO ▶
VERT. SYNC.	◀	AUTO ▶
SHUTTER(U)	◀	0 ▶
SHUTTER(L)	◀	0 ▶

### User memory for signal setting

This projector can memorize the maximum of 2 signal menu settings.

#### Memorizing the setting

1. Select MEMORIZE in the SIGNAL menu, and press the ENTER button.
2. Press the ◀ or ▶ button to select the memory which you wish to record (USER 1 or USER 2).
3. Press the ENTER button.

#### Initialite the setting which has been changed (Default)

Select RESET in the SIGNAL menu, and press the ENTER button.

- When initializing, selection buttons will not work for about 2 - 18 seconds.

#### Select the user setting

Select MEMORY CALL in SIGNAL menu, and press the ◀ or ▶ button to select the memory (USER 1 or USER 2).

#### Reset the recorded setting

1. Select DELETE in the SIGNAL menu, and press the ENTER button.
2. Press the ◀ or ▶ button to select the memory which you wish to reset (USER 1 or USER 2).
3. Press the ENTER button.

The recorded setting will be reset.

[FixYourDLP.com](http://FixYourDLP.com)

at the recorded setting

[www.Account-Merchant.com](http://www.Account-Merchant.com) (800) 281-8860

THE TRUSTED SOURCE FOR PROJECTOR LAMPS AND ACCESSORIES

# Picture adjustment

## Adjusting the image

You can adjust the picture by using the IMAGE menu.

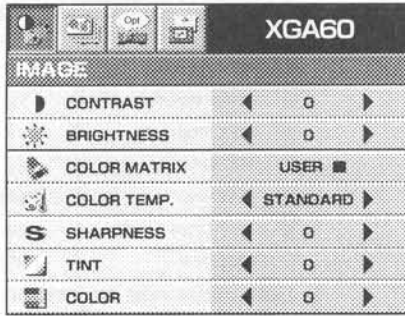

### To control the level of white-to-black in the image :

Adjust CONTRAST in IMAGE menu. Press the ► button to increase the contrast and the ◀ button to reduce it.

### To control the light level of the image :

Adjust BRIGHTNESS in IMAGE menu. Press the ► button to lighten the image and the ◀ button to darken the image.

### To adjust the detail and clarity of the image :

Adjust SHARPNESS in IMAGE menu. Press the ► button to make the picture seem sharper and the ◀ button to make it softer.

### To determine the intensity of the color :

Adjust COLOR in IMAGE menu. Press the ► button to increase the amount of color in the image and the ◀ button to decrease it.

### To adjust the red-green color balance of the image :

Adjust TINT in IMAGE menu. Press the ► button to increase the amount of red in the image and the ◀ button to increase the amount of green in the image.

## Color matrix

This feature adjusts the color balance in each color of RGB (Red, Green, Blue), and their neutral colors (yellow, cyan, magenta) by using Color correction adjustment. Use Color correct adjustment when emphasizing a specific color, or when only a certain color balance is not correctly adjusted.

1. Select COLOR MATRIX in IMAGE menu.
2. Press the ENTER button.



### When using the setting which has been already prepared

3. Press the ◀ or ► button to select 1, 2, or 3.
  - Select OFF when not using Color matrix adjustment

### When using the user setting

4. Press the ◀ or ► button to select USER ▼.
5. Press the ▲ or ▼ button to select the desired color.
6. Press the ◀ or ► button to adjust the color balance of the color.
7. Repeat steps 5 and 6 for more adjusting.
8. Exit the menu system by pressing the MENU button several times.

## Color temperature

1. Select COLOR TEMP in IMAGE menu.
2. Press the ◀ or ► button to select USER ■.
3. Press the ENTER button.



4. Press the ▲ or ▼ button to select the desired item.
5. Press the ◀ or ► button to adjust the item.
6. Repeat steps 4 and 5 for more adjusting.
7. Exit the menu system by pressing the MENU button several times.

### About color temperature

There are different kinds of white color. Color temperature is a way to show the differences. The white, which temperature is low, becomes raddish white. When the color temperature is higher, the white becomes more bluish. This projector sets this color temperature by changing the numbers of contrast blue and red.

To set the color temperature high:

Set the contrast B (Blue) number high, and the contrast R (Red) number low.

To set the color temperature low:

Set the contrast B (Blue) number low, and the contrast R (Red) number high.

**Adjustment from personal computer**

Although this projector sets proper signal systems automatically for the image signal from personal computers, it cannot be applied to some of personal computers. In this case, press the AUTO POSITION button. If the images are still not projected correctly, use the MENU display to adjust the projected images.

XGA60		
SIGNAL		
MEMORY CALL	◀	AUTO ▶
HORIZ. POSITION	◀	208 ▶
VERT. POSITION	◀	22 ▶
FINE SYNC.	◀	24 ▶
TRACKING	◀	1056 ▶
COMPUTER INPUT	◀	RGB ▶
HOLD	◀	AUTO ▶
USER	MEMORIZE	DELETE
■	■	■

**Image moved to right or left :**

Adjust HORIZ. POSITION in SIGNAL menu. Press the ▶ button to move the image to left. Press the ◀ button to move the image to right.

**Image moved to up or down :**

Adjust VERT. POSITION in SIGNAL menu. Press the ▶ button to move the image to upward. Press the ◀ button to move the image to down.

**Image flickers / Image is out of focus :**

Adjust FINE SYNC. in SIGNAL menu.

**Top part of image curves :**

Change the setting of HOLD in SIGNAL menu or PLL in SIGNAL - USER menu.

HOLD ... Select ON, and adjust BEGIN or END for image which top part is the least curved.

PLL ..... Select FAST, NORMAL, or SLOW for an image in which top part is the least curved. Select AUTO for normal setting.

**Image does not move naturally :**

Adjust VERT. SYNC. of the menu in SIGNAL - USER menu. Select AUTO for normal setting. curved. Select AUTO for normal setting.

- Do not change each menu setting in USER menu for normal setting.

**Simple adjustment method**

1. Select HORIZ. POSITION in SIGNAL menu.
2. Press the ◀ or ▶ button to adjust the horizontal start position (the left end).
3. Select TRACKING in SIGNAL menu.
4. Press the ◀ or ▶ button to adjust the horizontal end position (the right end).
5. Repeat steps 1 to 4 for fine adjustment.
6. Select VERT. POSITION in SIGNAL menu.
7. Press the ◀ or ▶ button to adjust the vertical start position (the top end).

SIGNAL - USER		
CLAMP POSITION	◀	0 ▶
CLAMP WIDTH	◀	+ 5 ▶
HORIZ. PIXELS	◀	800 ▶
VERT. LINES	◀	600 ▶
PLL	◀	AUTO ▶
VERT. SYNC.	◀	AUTO ▶
SHUTTER(U)	◀	0 ▶
SHUTTER(L)	◀	0 ▶

**Wide stripes appear :**

Adjust CLAMP POSITION or CLAMP WIDTH of each menu in SIGNAL - USER menu.

**Noise etc. appears on right or left side of image :**

Adjust HORIZ. PIXELS of the menu in SIGNAL - USER menu.

**etc. appears on top or bottom part of image**

Adjust SHUTTER (U), SHUTTER (L) or VERT. LINES of the menu in SIGNAL - USER menu.

FixYourDLP.com  
 DiscountMerchant.com (800) 281-8860  
 THE TRUSTED SOURCE FOR PROJECTOR LAMPS AND ACCESSORIES

## Picture adjustment (continued)

### Specification of RGB signals in each computer mode of the projector

For 338 / 350

Signal mode	resolution (H x V)	horizontal frequency (kHz)	Vertical frequency (Hz)	Normal mode (H x V)	Real mode (H x V)
TV60	-	15.73	59.94	1024 x 768	-
TV50	-	15.63	50.00	1024 x 768	-
1080i	-	33.75	60.00	1024 x 576	-
720p	-	45.00	60.00	1024 x 576	-
PC98	640 x 400	24.82	56.42	1024 x 640	640 x 400
CGA70	640 x 400	31.47	70.09	1024 x 640	640 x 400
CGA85	640 x 400	37.86	85.08	1024 x 640	640 x 400
VGA60	640 x 480	31.47	59.94	1024 x 768	640 x 480
VGA72	640 x 480	37.86	72.81	1024 x 768	640 x 480
VGA75	640 x 480	37.50	75.00	1024 x 768	640 x 480
VGA85	640 x 480	43.27	85.01	1024 x 768	640 x 480
SVGA56	800 x 600	35.16	56.25	1024 x 768	800 x 600
SVGA60	800 x 600	37.88	60.32	1024 x 768	800 x 600
SVGA72	800 x 600	48.08	72.19	1024 x 768	800 x 600
SVGA75	800 x 600	46.88	75.00	1024 x 768	800 x 600
SVGA85	800 x 600	53.67	85.06	1024 x 768	800 x 600
XGA43i	1024 x 768	35.52	86.96	1024 x 768	1024 x 768
XGA60	1024 x 768	48.36	60.00	1024 x 768	1024 x 768
XGA70	1024 x 768	56.48	70.07	1024 x 768	1024 x 768
XGA75	1024 x 768	60.02	75.03	1024 x 768	1024 x 768
XGA85	1024 x 768	68.68	85.00	1024 x 768	1024 x 768
SXGA70a	1152 x 864	63.85	70.01	1024 x 768	1024 x 768
SXGA75a	1152 x 864	67.50	75.00	1024 x 768	1024 x 768
SXGA85a	1152 x 864	77.49	85.06	1024 x 768	1024 x 768
SXGA60a	1280 x 960	60.00	60.00	1024 x 768	1024 x 768
SXGA75a	1280 x 960	75.00	75.00	1024 x 768	1024 x 768
SXGA43i	1280 x 1024	46.43	86.87	1024 x 768	1024 x 768
SXGA60	1280 x 1024	63.98	60.02	1024 x 768	1024 x 768
SXGA75	1280 x 1024	79.98	75.03	1024 x 768	1024 x 768
SXGA85	1280 x 1024	91.15	85.02	1024 x 768	1024 x 768
MAC13	640 x 480	35.00	66.67	1024 x 768	640 x 480
MAC16	832 x 624	49.72	74.55	1024 x 768	832 x 624
MAC19	1024 x 768	60.24	75.02	1024 x 768	1024 x 768
MAC21	1152 x 870	68.59	74.96	1024 x 768	1024 x 768
HP75	1024 x 768	62.94	74.92	1024 x 768	1024 x 768
HP72	1280 x 1024	78.13	72.00	1024 x 768	1024 x 768
SUN66a	1152 x 900	61.85	66.00	1024 x 768	1024 x 768
SUN76a	1152 x 900	71.81	76.63	1024 x 768	1024 x 768
SUN66	1280 x 1024	71.68	66.68	1024 x 768	1024 x 768
SUN76	1280 x 1024	81.13	76.11	1024 x 768	1024 x 768
SGI72	1280 x 1024	76.92	72.30	1024 x 768	1024 x 768
SGI76	1280 x 1024	82.00	76.00	1024 x 768	1024 x 768
IBM60	1280 x 1024	63.42	60.00	1024 x 768	1024 x 768

- When the EXPAND MODE of FEATURE menu is set to 4, by pressing the EXPAND button on the remote control, it will switch to the screen displaying the picture as its original size (real screen display). In the real screen display, pictures will be black-framed when picture resolution is lower than 1,024 x 768.

#### Important:

- Some computers may not be compatible with the projector.
- The projector's maximum resolution is 1,024 x 768 pixels. It may not display correctly for the pictures of higher resolutions than 1,024 x 768.
- The picture with a SYNC on G (Green) signal may jitter.
- The picture with a SYNC on G (Green) signal may be tinged with green.

- If the resolution and frequency of your computer are not shown on the table, change the resolution of your computer. You may find the compatible resolution and frequency.
- Set the COMPUTER INPUT in SIGNAL menu to RGB, when inputting the HDTV signal as RGB signal.
- Set the SIGNAL menu and USER menu as shown below, when 525p signal is inputted.

HORIZ. POSITION ..... 143  
 VERT. POSITION ..... 54  
 TRACKING ..... 800  
 COMPUTER INPUT ..... YC<sub>B</sub>Cr/YP<sub>B</sub>Pr  
 CLAMP POSITION ..... +9  
 CLAMP WIDTH ..... +3  
 HORIZ. PIXELS ..... 620  
 VERT. LINES ..... 444  
 VERT. SYNC ..... ON

**Specification of RGB signals in each computer mode of the projector**

**For 238**

Signal mode	resolution (H x V)	horizontal frequency (kHz)	Vertical frequency (Hz)	Normal mode (H x V)	Real mode (H x V)
TV60	–	15.73	59.94	800 x 600	–
TV50	–	15.63	50.00	800 x 600	–
1080i	–	33.75	60.00	800 x 450	–
720p	–	45.00	60.00	800 x 450	–
PC98	640 x 400	24.82	56.42	800 x 500	640 x 400
CGA70	640 x 400	31.47	70.09	800 x 500	640 x 400
CGA84	640 x 400	37.86	84.14	800 x 500	640 x 400
CGA85	640 x 400	37.86	85.08	800 x 500	640 x 400
VGA60	640 x 480	31.47	59.94	800 x 600	640 x 480
VGA72	640 x 480	37.86	72.81	800 x 600	640 x 480
VGA75	640 x 480	37.50	75.00	800 x 600	640 x 480
VGA85	640 x 480	43.27	85.01	800 x 600	640 x 480
SVGA56	800 x 600	35.16	56.25	800 x 600	800 x 600
SVGA60	800 x 600	37.88	60.32	800 x 600	800 x 600
SVGA72	800 x 600	48.08	72.19	800 x 600	800 x 600
SVGA75	800 x 600	46.88	75.00	800 x 600	800 x 600
SVGA85	800 x 600	53.67	85.06	800 x 600	800 x 600
XGA43i	1024 x 768	35.52	86.96	800 x 600	800 x 600
XGA60	1024 x 768	48.36	60.00	800 x 600	800 x 600
XGA70	1024 x 768	56.48	70.07	800 x 600	800 x 600
XGA75	1024 x 768	60.02	75.03	800 x 600	800 x 600
XGA85	1024 x 768	68.68	85.00	1024 x 768	800 x 600
MAC13	640 x 480	35.00	66.67	1024 x 768	640 x 480
MAC16	832 x 624	49.72	74.55	1024 x 768	800 x 600
MAC19	1024 x 768	60.24	75.02	1024 x 768	800 x 600
MAC21	1152 x 870	68.59	74.96	1024 x 768	800 x 600
HP75	1024 x 768	62.94	74.92	1024 x 768	800 x 600

- When the EXPAND MODE of FEATURE menu is set to 2, by pressing the EXPAND button on the remote control, it will switch to the screen displaying the picture as its original size (real screen display). In the real screen display, pictures will be black-framed when picture resolution is lower than 800 x 600.

**Important:**

- Some computers may not be compatible with the projector.
- The projector's maximum resolution is 800 x 600 pixels. It may not display correctly for the pictures of higher resolutions than 800 x 600.
- The picture with a SYNC on G (Green) signal may jitter.
- The picture with a SYNC on G (Green) signal may be tinged with green.

- If the resolution and frequency of your computer are not shown on the table, change the resolution of your computer. You may find the compatible resolution and frequency.
- Set the COMPUTER INPUT in SIGNAL menu to RGB, when inputting the HDTV signal as RGB signal.
- Set the SIGNAL menu and USER menu as shown below, when 525p signal is inputted.

HORIZ. POSITION ..... 143  
 VERT. POSITION ..... 54  
 TRACKING ..... 800  
 COMPUTER INPUT ..... YCbCr/YPbPr  
 CLAMP POSITION ..... +9  
 CLAMP WIDTH ..... +3  
 HORIZ.PIXELS ..... 620  
 VERT.LINES..... 444  
 VERT.SYNC..... ON



**Discount-Merchant.com (800) 281-8860**  
**THE TRUSTED SOURCE FOR PROJECTOR LAMPS AND ACCESSORIES**

ENGLISH

# Advanced features for presentation

## Expand

By pressing the EXPAND button on the remote control, you can magnify the detailed image of the picture. You can also view the screen displaying the picture as its original size (native resolution display).

### Setting the Expand mode

1. Press the MENU button.
2. Press the ◀ or ▶ to select the FEATURE menu.
3. Press the ENTER button.
4. Press the ▲ or ▼ button to select EXPAND MODE or FRAME POSI.
5. Press the ◀ or ▶ to set the EXPAND MODE or FRAME POSI.
6. Press the MENU button twice to exit the menu system.

### EXPAND MODE (For 350)

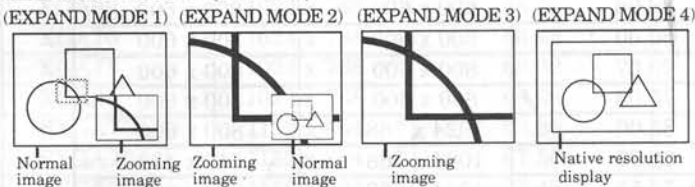

### EXPAND MODE (For 238 / 338)

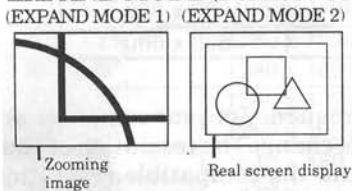

### FRAME POSI. (For 350 only)

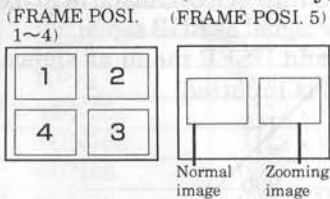

### Using the Expand mode

1. Press the EXPAND button.
  - You can magnify different areas of the active picture by pressing the ▲, ▼, ◀, ▶ button.
  - You can change the magnification of the zoomed area by pressing the + or - button.

[FixYourDLP.com](http://FixYourDLP.com)

Press the EXPAND button twice on the remote control.

The normal screen display will appear on the screen.

- Display enlargement does not work with video input or S-video input.
- In EXPAND mode, you cannot adjust the zoom/focus and the volume.

## REAL screen display

- During REAL mode, Press the ◀ or ▶ buttons for fine adjustment. The ▲ and ▼ buttons are not working at this time.
- The expanding rate cannot be changed by pressing either the + or - button. They are working for volume adjustment.

## For 350 only

### Picture in Picture (PinP)

One of the special features of this unit is the picture in-picture (PinP) mode. PinP allows you to view different sources at the same time.

### Using the PinP mode

1. Press the PinP button on the remote control.
  - Pressing the PinP button repeatedly will select on and off.

To switch Main image and Sub image

2. Press the ◀ or ▶ buttons on the remote control.

To change frame position

### FRAME POSI.

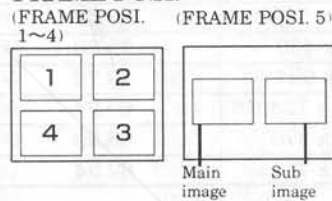

3. Press the ▲ or ▼ buttons on the remote control.
4. Press the PinP button on the remote control. The sub image will be disappear.

- Adjusting contrast, brightness, tint or color isn't available in PinP mode.
- In PinP mode, both Main image and Sub image are displayed with their frames skipped.
- In PinP mode, the audio of the Main image is outputted.
- In PinP mode, the images may not move smoothly.

## Still

How to stop the picture temporarily (still picture)

1. Press the STILL button on the remote control. The picture will be frozen temporary.

To resume picture activity.

2. Press the STILL button on the remote control again.

## Mouse remote control

By connecting to personal computer through the USB, PS/2 or ADB port, you can operate your computer with the projector remote control.

### Connection

#### Projector + PC through USB connector

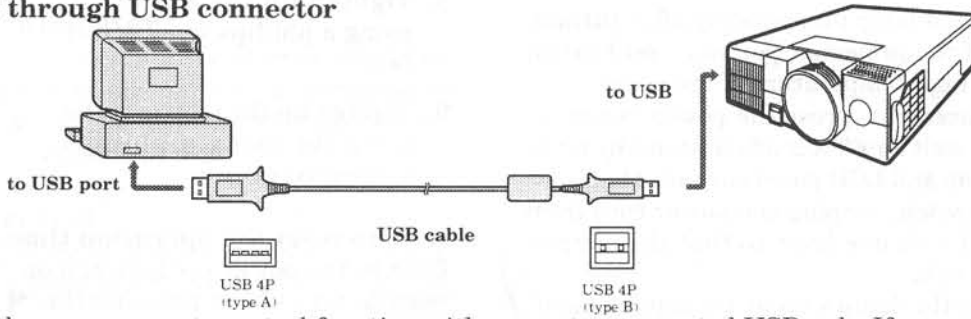

- You can use the mouse remote control function with computer supported USB only. If your system is Windows® 98 or higher, your computer supported USB in standard. If your system is Windows® 95 or lower, please contact your dealer. If your computer is Macintosh with USB port, you can use this function.
- When the lamp is turned ON, the computer connected with the USB cable may not work correctly. In this case, restart the projector and the computer. If possible, you should disconnect the USB cable when the lamp is turned ON.

#### Projector + IBM PC or IBM PC compatibles

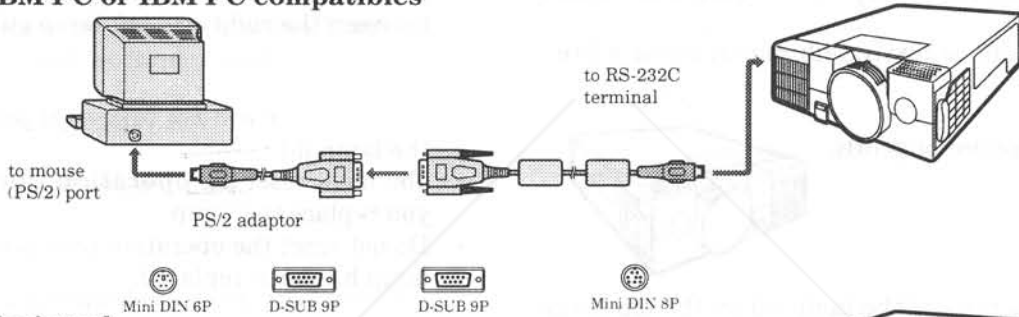

#### Projector + Macintosh

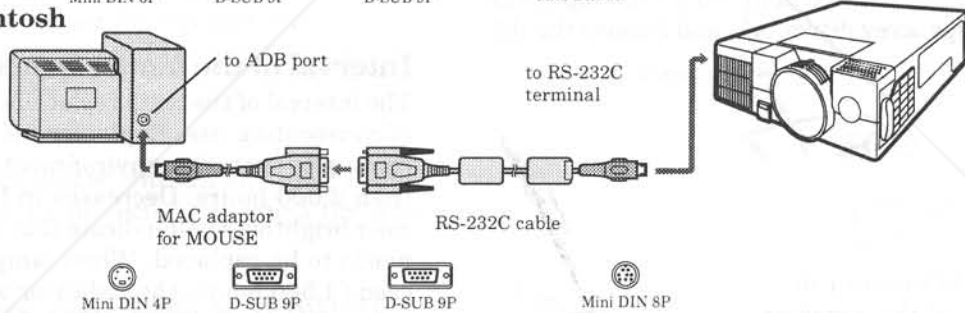

- Turn off PC and the projector before connecting with PS/2 port or ADB port. When connecting the PC with the projector when the personal computer is on, the remote control does not work as a mouse. In that case, restart the personal computer.
- When the projector is connected with USB terminal and RS-232C terminal at the same time, only the terminal which the projector recognizes first will work.

### Operation

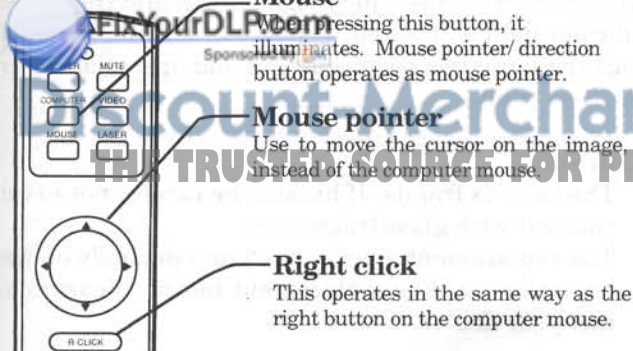

**Left click**  
This operates in the same way as the left button on the computer.



- When L/R click buttons and the mouse button are not used for 6 seconds, the mode will be changed to the normal mode automatically.



# Lamp replacement

The lamp is designed to project the image on the LCD panels. When the lamp no longer functions, replace it with a new one.

## Caution:

- Do not remove the lamp immediately after turning off the lamp of the projector, you may get burned because of the high temperature of the lamp.
- For lamp replacement, press the power button to power off, then wait for 60 seconds in stand-by mode to allow the lamp and LCD panels to cool. Then turn off the main switch, unplug the power cord from the outlet, and wait one hour so that the lamp is cooled to the touch.
- Do not remove the lamp except for replacement. Careless treatment can cause injury or fire.
- Do not touch the lamp element directly. It may break and cause you to injure or burn yourself.
- Be sure not to drop the lamp lid screw into the projector. Also be sure not to insert metal or any flammable objects, it may cause fire or electric shock. If any objects are inserted, please unplug and contact your dealer.
- Install the lamp securely, failure may cause a fire.

1. Reverse the projector gently.

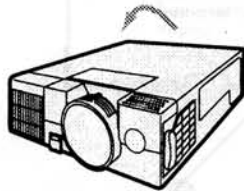

2. Loosen the screws of the lamp lid on the top cover using a phillips screwdriver (+), and remove the lid.

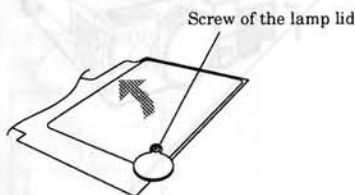

- Remove the lamp cover in the direction of the arrow as indicated.
3. Loosen screws (a) using a phillips screwdriver (+).
  4. Pull up the handle.

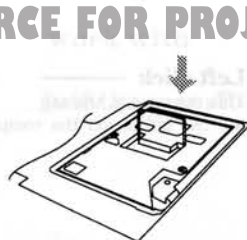
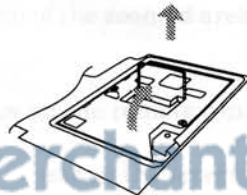
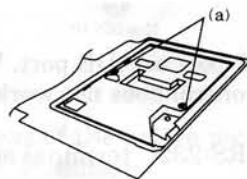

- Hold onto the projector by the handle as you pull out the lamp.
- Once the lamp has been removed, do not spill liquid on it, place it near flammable objects or where children can touch it. Otherwise, it will cause injury or fire.
6. Insert the new lamp securely into the projector body in the right direction.

7. Put the handle back to the holding point.
  - Make sure that the handle is locked.

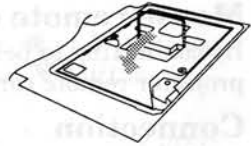

8. Tighten up the screws (a) using a phillips screwdriver (+).
9. Tighten up the screws of the lamp lid using a phillips screwdriver (+).

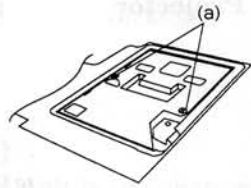

## How to reset the operation time meter

Plug in the power cord, switch on the projector, and reset lamp time by pressing the ◀, ▶ and POWER buttons simultaneously.

## Caution:

- Do not spill liquid on the lamp or place it near flammable objects or where children can touch it. Otherwise, it could cause injury or fire.
- Be sure that the projector guide is firmly inserted between the right and left lamp guides.

## Important:

- The projector will not turn on if you do not secure the lamp lid.
- You must reset the **operation time meter** after you replace the lamp.
- Do not reset the operation time meter unless the lamp has been replaced.

## Interval of the lamp replacement

The interval of the lamp replacement about 2,000 hours of consecutive use. Replacement span may differ according to operating environment, and may be shorter than 2,000 hours. Decreases in luminescence and/or color brightness will indicate that the light source lamp needs to be replaced. When lamp operation time exceeds 1,500 hours, the indicator will flash alternately between green and red (while the lamp is in operation; when the lamp is not in operation, the indicator will appear red only). When the lamp has been used for about 1,900 hours, the message "LAMP!!." will appear on the screen for one minute. When the lamp has been used for about 2,000 hours, the projector will automatically shut off for the safety of the lamp and the power indicator light will be red. The projector cannot be used until the lamp has been replaced and operation timer has been reset.

## Caution:

- The lamp is fragile. If broken, be careful not to cut yourself with glass fragments.
- The replacement span of the lamp depends on the environment. For replacement lamps, please contact your dealer.

**The projector automatically shuts off after about 2,000 hours, and you cannot use the projector until you replace the lamp.**

# Maintenance

## Caution:

Be sure to turn off the projector and unplug the power cord from the wall outlet before you perform any maintenance on the projector.

## Cleaning the air-filter

Clean the air-filter frequently. If the filter or ventilation grill become clogged with dirt or dust, the temperature inside the projector may rise and shut off the power (the TEMP indicator starts to blink red).

### For side air inlet grill

1. To remove the filter cover, press the ridged area gently, push the cover in the direction of the arrow and lift.
2. Remove the air-filter from the filter cover.
3. Wash the air-filter.
  - Use water or a mild detergent diluted with water to clean the filter. Rinse the filter thoroughly and let it dry completely.
4. Attach the filter to the cover.
5. Reinstall the filter cover.

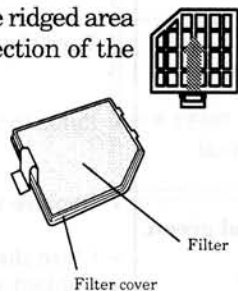

## Cleaning the lens

Use a standard lens-cleaning brush or a piece of lens tissue dampened with lens cleaning fluid. The lens surface is fragile. Use only recommended, nonabrasive lens-cleaning materials. Do not touch the lens with your fingers.

## Important:

- If the filter is damaged or becomes extremely dirty, contact your dealer for replacement.
- The power will not turn on if the air-filter cover is improperly installed.

## Caution:

Be sure to use the projector with an air-filter. If not, dust may get inside the projector, causing a fire or a breakdown.

## Cleaning the projector and the ventilation grill

Use a soft cloth to clean the projector and the ventilation grill. When the grill become dirty, wipe them with a soft cloth dampened with a diluted mild detergent, and then wipe them with a dry cloth.

To protect the surface of the projector from fading or

- Do not spray insecticide on or inside the projector.
- Do not use benzine or thinner to clean it.
- Do not let rubber or plastic materials come into contact with the projector.

# Troubleshooting

The following offers solutions to some of the common problems you may encounter. We suggest that you consult this chart before contacting your dealer.

PROBLEMS	CAUSE	POSSIBLE SOLUTIONS
The power is off.	<ul style="list-style-type: none"> <li>The air inlet grill, outlet grill or air filter is clogged with dust or some objects.</li> </ul> <p><b>POWER indicator does not light up.</b></p> <ul style="list-style-type: none"> <li>Power cord is unplugged from the outlet.</li> <li>Power cord is disconnected from the projector.</li> <li>The main switch is turned off.</li> <li>The lamp lid is open.</li> </ul> <p><b>POWER indicator blinks red.</b></p> <ul style="list-style-type: none"> <li>The projector has been turned on again too soon after having been turned off.</li> <li>When the power switch was turned off while the fan was running, during or after lamp operation.</li> <li>The room temperature is too high. (Does the LAMP indicator show an unusual condition?)</li> <li>Lamp is no longer working.</li> </ul> <p><b>POWER indicator blinks between red and green.</b></p> <ul style="list-style-type: none"> <li>The filter cover is not closed.</li> <li>When the LAMP indicator or the TEMP indicator is either on or blinking, the main unit requires repairs.</li> </ul>	<ul style="list-style-type: none"> <li>Remove the object.</li> <li>Plug the power cord into the outlet.</li> <li>Insert the power cord into the projector.</li> <li>Turn the main switch on.</li> <li>Close the lamp lid.</li> <li>Wait for the lighting sequence.</li> <li>Turn the power switch on and off several times.</li> <li>Refer to "Indicators" on page 27.</li> <li>Replace the lamp with a new one.</li> <li>Close the cover correctly.</li> <li>Contact your dealer.</li> </ul>
No picture appears on the screen.	<ul style="list-style-type: none"> <li>Lens is covered by lens cap.</li> <li>When the LAMP indicator or the TEMP indicator is either on or blinking, the main unit requires repairs.</li> <li>The equipment connected to this projector is not turned on.</li> <li>Hookup is not made correctly with other equipment.</li> <li>The input source is not selected correctly.</li> </ul>	<ul style="list-style-type: none"> <li>Take the lens cap off.</li> <li>Replace the lamp with a new one.</li> <li>Turn on the connected equipment.</li> <li>Confirm the hookup.</li> <li>Select the correct source according to the equipment connected to this projector.</li> </ul>
The image is turned off.	<ul style="list-style-type: none"> <li>The air inlet grill, outlet grill or air filter is clogged with dust or some objects. (In this case, the TEMP indicator does not light up.)</li> </ul>	<ul style="list-style-type: none"> <li>Remove the object and turn off the main power switch. After about 10 minutes, Turn the projector on.</li> </ul>
The image is distorted.	<ul style="list-style-type: none"> <li>The projector is not at a right angle to the screen.</li> </ul>	<ul style="list-style-type: none"> <li>Adjust the angle of the projector to make a right angle to the screen. See page 12.</li> </ul>
The image is dark.	<ul style="list-style-type: none"> <li>Brightness, tint and color are not adjusted correctly.</li> </ul>	<ul style="list-style-type: none"> <li>Adjust brightness, tint and color correctly.</li> </ul>
The image is blurred.	<ul style="list-style-type: none"> <li>The projecting distance is beyond the focused area.</li> <li>Lens is dirty.</li> <li>Screen size exceeds screen size specifications.</li> <li>Brightness and contrast are not adjusted correctly.</li> <li>FINE adjustment is not made correctly.</li> <li>Tracking is not adjusted.</li> <li>The projector is not at a right angle to the screen.</li> </ul>	<ul style="list-style-type: none"> <li>Adjust the projecting distance. See page 9.</li> <li>Clean lens.</li> <li>Reduce screen size to within 40" to 300".</li> <li>Adjust brightness, contrast.</li> <li>Make FINE adjustment.</li> <li>Adjust tracking.</li> <li>Adjust the angle of the projector to make a right angle to the screen. See page 12.</li> </ul>
The image remains blurred.	<ul style="list-style-type: none"> <li>When you see the stationary image for a long time, it may remain on the screen if you change the image. It is not a breakdown. The blurred image will disappear in a few minutes.</li> </ul>	
Red, blue or green dots are overlaid on the text of image.	<ul style="list-style-type: none"> <li>It is normal.</li> </ul>	
The image is distorted on the screen and noise is heard.	<ul style="list-style-type: none"> <li>The cable for connection with other equipment is not plugged securely into the terminal.</li> <li>The projector is installed too close to other equipment.</li> </ul>	<ul style="list-style-type: none"> <li>Plug the connecting cable securely into the terminal. See pages 10-11.</li> <li>Install the projector far away from other equipment.</li> </ul>
No sound is heard.	<ul style="list-style-type: none"> <li>Volume is not turned up.</li> <li>Connection to other equipment is not made correctly.</li> </ul>	<ul style="list-style-type: none"> <li>Turn up the volume.</li> <li>Check connections. See pages 10-11.</li> </ul>
Nothing is displayed on the PC monitor.	<ul style="list-style-type: none"> <li>The PC monitor is not turned on.</li> </ul>	<ul style="list-style-type: none"> <li>Turn on the monitor.</li> </ul>
Warm air comes out of the exhaust vents.	<ul style="list-style-type: none"> <li>This is typical of the LCD projector.</li> </ul>	
Adjustments cannot be made.	<ul style="list-style-type: none"> <li>The operation is incorrectly made due to noise or interference.</li> </ul>	<ul style="list-style-type: none"> <li>Press the reset button on the Terminal board. See page 15.</li> </ul>

# Indicators

The projector has three LED Indicators which shows the working condition of the projector.

The following offers solutions to possible problems. If a problem persists, turn the projector off and consult your dealer.

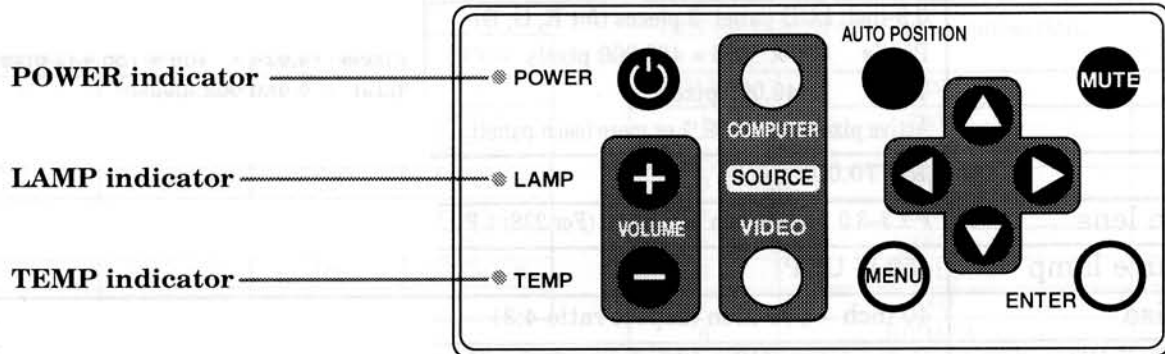

## Normal condition

POWER	LAMP	TEMP	CONDITION	Notes
Steady red	Off	Off	Stand-by	
Steady green	Blinking green	Off	Lamp stand-by (about for 1 minute)	The power button cannot be used to switch ON and OFF
Steady green	Steady green	Off	The POWER is ON. (Normal condition)	

## Abnormal condition

POWER	LAMP	TEMP	CONDITION	POSSIBLE SOLUTIONS
Steady green	Steady green	Blinking red	Unusual temperature <ul style="list-style-type: none"> <li>The ventilation slits or air filter is clogged with dust or debris.</li> <li>The fan has stopped due to an impediment.</li> </ul>	<ul style="list-style-type: none"> <li>Remove the object from the ventilation slits.</li> <li>Pull out the power plug and remove the object. If you cannot, consult your dealer.</li> <li>Relocate the projector to a cooler place.</li> <li>Clean the filter.</li> </ul>
Steady red	Off	Blinking red	<ul style="list-style-type: none"> <li>The room temperature is too high.</li> <li>The filter is dirty.</li> </ul>	
Steady green	Blinking green/red	Off	Lamp duration warning. (Lightning duration total about 1,500 hours. When the POWER is ON.)	Replace the lamp. Exchange with a new lamp if the same problem recurs.
Steady red	Blinking red	Off	Lamp duration warning. (Lightning duration total about 1,500 hours. When the POWER is OFF.)	
Steady red	Off	Off	Lamp duration warning. (Lightning duration total about 2,000 hours.)	
Blinking green/red	Off	Off	The lamp or filter cover is not closed.	Close the cover correctly.
Blinking green/red	Steady or Blinking	Steady or Blinking	Abnormal.	Contact your dealer.

# Specifications

Type	LCD projector	
Model	238   338   350	
Rated power supply	AC100V ~ 240V, 50 / 60Hz	
Rated input	2.3 A	
LCD panels	238	338   350
	0.9-inch LCD panel: 3 pieces (for R, G, B) Pixels 800 × 600 = 480,000 pixels Total 1,440,000 pixels Active pixel rate: 99.99 % or more (each panel)	0.9-inch LCD panel: 3 pieces (for R, G, B) Pixels 1,024 × 768 = 786,432 pixels Total 2,359,296 pixels Active pixel rate: 99.99 % or more (each panel)
Colors	16,770,000 colors	
Projection lens	F 2.3~3.0 f= 36.0 mm ~ 57.6 mm (For 238)   F 1.7~2.0 f= 33.2 mm ~ 43.1 mm (For 338   350)	
Light source lamp	150 W UHP	
Picture size	40 inch ~ 300 inch (aspect ratio 4:3)	
PC compatibility	Resolution : 640 x 400 - 800 x 600 + Compressed 1024 x 768 (For 238) Resolution : 640 x 400 - 1024 x 768 + Compressed 1280 x 1024 (For 338   350) Sync on Green available	
Video compatibility	NTSC / NTSC 4.43 / PAL (including PAL-M, N) / SECAM, PAL-60 DVD (Component) / HDTV (1080i) / 720p / (525p)	
Audio output	1 W mono	
Speaker	6 cm square type (8Ω 1W)	
S-video input	Luminance signal: V <sub>p-p</sub> =1.0V 75Ω (negative sync.) Chroma signal: V <sub>p-p</sub> =0.286V 75Ω (burst signal)	
Video input	V <sub>p-p</sub> =1.0V 75Ω (negative sync.)	
Audio inputs	350 mVrms, 10kΩ or more	
Analog RGB input (mini D-SUB 15P)	RGB: V <sub>p-p</sub> =0.7V 75Ω (negative sync.) Y <sub>CbCr</sub> : Y: V <sub>p-p</sub> =1.0V (negative sync.) C <sub>b</sub> C <sub>r</sub> : V <sub>p-p</sub> =0.7V HD/CS : TTL level (positive or negative) VD : TTL level (positive or negative)	
Control connector	Serial (DIN 8 pin female connector) RS-232C standards PS/2 (Mouse function), USB terminal for Mouse	
Outside dimensions	242 mm × 79 mm × 294 mm (9.5 inch × 3.1 inch × 11.6 inch) (width × height × depth)                      Legs and lens are not included.	
Weight	Approx. 3.2 kg (7 lbs)	
Length of power cord	2.9m (9.5 feet)	
Temperature, humidity (performance guarantee)	+41°F (+5°C) ~ +95°F (+35°C), 30~90%	

## Kensington Lock

This projector has a Kensington Security Standard connector for use with a Kensington MicroSaver Security System. Refer to the information that came with the Kensington System for instructions on how to use it to secure the projector. Please contact to Kensington Technology Group as shown below.

Kensington Technology Group  
2855 Campus Drive  
San Mateo, CA 94403, U.S.A.

Phone : (650)572-2700 Fax : (650)572-9675

## Connectors

### PC analog RGB input

Use to input video signals (analog RGB) of a personal computer.

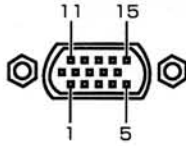

(Pin assignment of Mini D-SUB 15P jack)

PIN NO.	SPEC	PIN NO.	SPEC
1	R(RED)/C <sub>R</sub>	9	—
2	G(GREEN)/Y	10	GROUND
3	B(BLUE)/C <sub>B</sub>	11	GROUND
4	GROUND	12	DDC-DATA
5	GROUND	13	HD/CS
6	GROUND	14	VD
7	GROUND	15	DDC-CLK
8	GROUND		

### RS-232C input

Use to control the projector with the personal computer, or control the personal computer with remote control. Use the provided RS-232C cable (Mini DIN 8P-D-SUB 9P) for the connection.

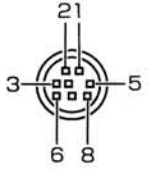

PIN NO.	NAME	I/O
1	TXD	IN
2	RTS	IN
3	DTR	IN
4	GND	—
5	CTS/5V	IN / OUT
6	DCD/CLOCK	OUT
7	RXD	OUT
8	RI/DATA	OUT

## Dimensional drawings

(mm)

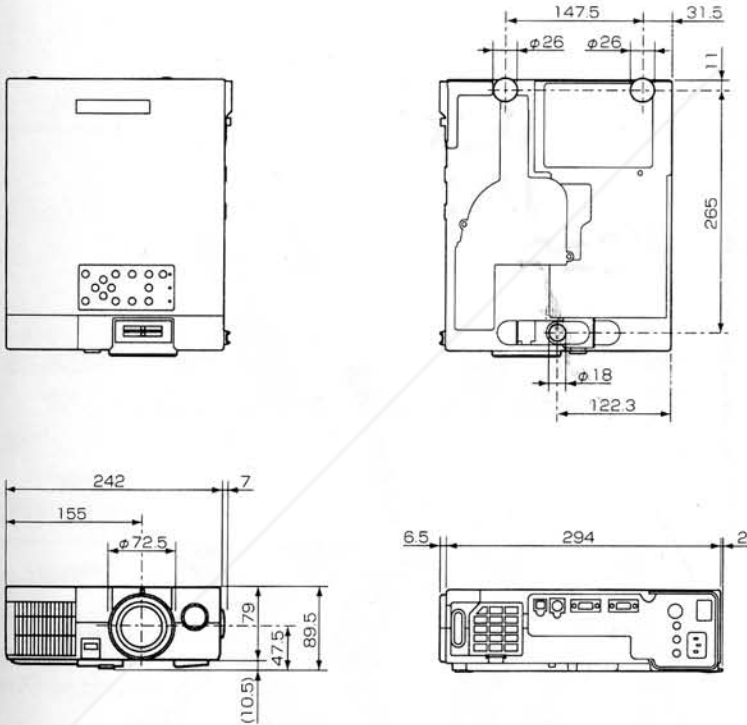

### What's included in the box

1 Power cable	246C383-10	1 USB cable	859C686-01
1 RCA video/audio cable	246C383-20	1 MAC adapter for MOUSE	246C368-10
1 S-video cable	246C381-10	1 Remote control	939P795-60 (238   338)
1 RGB cable for PC	859C687-01		939P795-30 (350)
1 MAC adapter for RGB cable	246C382-10	1 User manual	871D288-90
1 RS-232C cable	246C319-20	1 Quick reference card	857B031-10
1 MAC adapter for RS-232C cable	246C366-10	1 Registration card	854B331-20
1 PS/2 adapter	246C321-10	2 Battery for remote	—
	246C367-10	1 Carrying case	772P032-20

### Replacement part

(Option / Not included in the box)

Spare Mercury lamp 499B022-10 / PID 109823



# Disclaimer

This user manual is provided as a free service by FixYourDLP.com. FixYourDLP is in no way responsible for the content of this manual, nor do we guarantee its accuracy. FixYourDLP does not make any claim of copyright and all copyrights remain the property of their respective owners.

About FixYourDLP.com

FixYourDLP.com (<http://www.fixyourdlp.com>) is the World's #1 resource for media product news, reviews, do-it-yourself guides, and manuals.

Informational Blog: <http://www.fixyourdlp.com>

Video Guides: <http://www.fixyourdlp.com/guides>

User Forums: <http://www.fixyourdlp.com/forum>

FixYourDLP's Fight Against Counterfeit Lamps:

<http://www.fixyourdlp.com/counterfeits>

## Sponsors:

RecycleYourLamp.org – Free lamp recycling services for used lamps:

<http://www.recycleyourlamp.org>

Lamp Research - The trusted 3rd party lamp research company:

<http://www.lampresearch.com>

Discount-Merchant.com – The worlds largest lamp distributor:

<http://www.discount-merchant.com>



**FixYourDLP.com**

Sponsored by 